



Gantry Machining Center PM Series



* The content of the catalogue is subject to change without notice.

NEWAY CNC EQUIPMENT (SUZHOU) CO.,LTD.

No 69 Xunyangjiang Road,Suzhou New District, P.R.China

Tel: 86-512-6239 2186

Fax: 86-512-6607 1116

E-mail: cnccsale@neway.com.cn

www.newaycnc.com

NEWAY CNC (USA),INC.

9757 Stafford Centre Drive

Stafford,Texas 77477 USA

Tel: +1 281-969-5800

Fax: +1 281-969-5903

www.newaycnc.us

www.newaycnc.com

Neway Gantry Machining Center

Neway's Diverse New model line-up is designed and engineered to meet the World Class processing needs of several unique and different industries. The Quality and Repeatability of many of their zero-defect manufacturing processes have won the trust and praise of many repeat customers worldwide.

■ Stable Base Castings

All Major Components use high strength Meehanite casting for increased vibration absorption, resin sand molding, and then rests in a multi stage aging treatment to ensure stability. FEA designed integrated rib reinforcement, provides excellent bending and torsional stability, to ensure rigidity of the castings.

■ We Build For Your Application

Our diverse line-up offers a wide variety of already completed specifications, to meet the ever changing processing needs of different industries. Our machines excel in all types of aluminum alloy, cast iron, steel, and many other exotic materials and complicated parts processing.

■ Modern Modular Integrated Design

Modern Modular Design allows us rapid response to the special needs of customers; X/Y/Z axis travel from 1M to 12M to meet the requirements from small to very large workpiece processing; Slide guide, linear roller guide, Box way and the use of a square RAM and finally a T-shaped RAM make Neway suitable to meet the different requirements of customer's cutting feeds and speeds and cutting rigidity for the ultimate finish.

■ FEA and Other Advanced R&D Methods

Through the use of state-of-the-art computer technology All Major Components (bed, worktable, column, beam, saddle, RAM, etc.) are analyzed for static and dynamic characteristics and response by finite element analysis (FEA) to ensure the proper design for the best performance of the machine in the dynamic and static state.

■ Building for the Future with Much Higher Standards

Neway has added many new measurement, calibration and even thermal testing items. Each machine must complete a comprehensive final test cut inside the machine. With the addition of Boring and Vibration testing, we ensure that the machine tool operates well in a variety of complex cutting conditions to maintain stable, predictable operation.

CONTENTS

- 01-10 Characteristics Of Neway Gantry Machining Centers
- 11-19 PM-HA Series High-speed Gantry Machining Center
- 20-24 PM-L Series High-speed Direct Drive Spindle Gantry Machining Center
- 25-28 PM-V Series High-speed Built-in Spindle Gantry Machining Center
- 29-31 PM-U Series High-speed 5 Axis Gantry Machining Center
- 32-34 PMB-U Series High-speed 5 Axis Bridge Type Cross-rail Machining Center
- 35-40 PM-MH Series Movable Column Gantry Machining Center
- 41-42 Milling Heads
- 43 CNC System
- 44 More Options



01 High Stability

- All the major components utilize high strength Meehanite casting with high vibration absorption qualities. Each undergoes an aging treatment to ensure stress has been relieved and they can provide the utmost stability.
- Surpassing National Standards Neway added many new test items and a final proof cut. A pre delivery comprehensive test cut piece, final boring and vibration testing, ensures that the machine tool performs well in a variety of complex cutting and environmental conditions.

1 Neway World Class Casting Aging Treatment Process

Unlike the competition, We own our own Foundries. Six of them at this print. Our Casting's undergo heat aging, natural aging, vibration aging even chemical aging until the internal stress is fully released. Care is taken so that the precision base or headstock can be stable and reliable for a long time.



2 Arch Cable Suspended Bridge Design Beam with Special Rib Structure

Arch Cable-Bridge designed beam with FEA rib structure, effectively solves the problem of drooping over big span beams and significantly improves the y-axis processing and positioning accuracy. In pursuit of the optimal structure; the beam adopts engineered topological optimization techniques and special arrangement for internal structural strength. The mechanical analysis and optimization of the whole machine is to provide more weight bearing support and to decrease potential deflection that lesser quality machines suffer from.

3 Neway Transmission Design

Neway utilizes a combination of slide guide way and roller guide way, roller guide way are World Class and offer large-size roller guide ways and special heavy-duty, long-length slide roller blocks, to ensure smooth travel long-term stability.



4 Milling Head Test Lab

Neway built a comprehensive inspection and assembly Test Lab. With dozens of quality inspections already undergone, the assembled milling head is run in and indexed for a period of 48 hours in the actual operation to ensure the long-term use of the accessory milling head. This stringent testing provides a product that is both accurate and reliable and ready to go to work.



5 Three Guide Ways Design

Some models adopted three-guide design, they provide exceptional anti deformation under extreme loads when overturning torque is very strong. With heavy load bearing capacity, the worktable will not vibrate during heavy duty interrupted cutting; This insures the workpiece has a very good flatness and smoothness when needed for fine finishing.

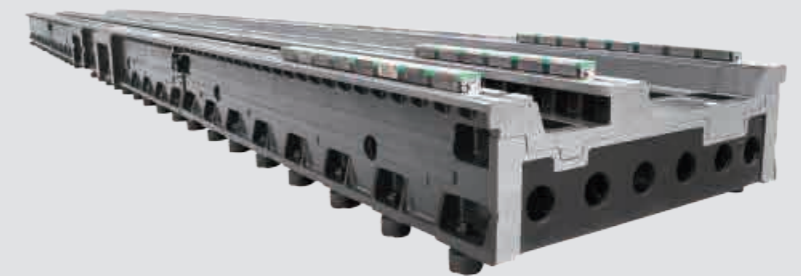

02 High Precision

Utilizing Neway Process Management for improved accuracy. Each process follows strictly controlled environment to ensure the build accuracy. Neway set their enterprise standards higher than National, significantly improving the positioning accuracy by more than 40%.

1 Word-class Machining Equipment

All Major parts of the gantry machining center are processed by World-class Mother Machines. Up to 20M parts can be precision ground on Favretto large size bed grinder. Because both surfaces can be processed in one set up the squareness and flatness which providing guaranteed qualified surfaces.



2 Bridge Beam Utilizes Anti Deformation Crown Treatment

To avoid the deforming of the beam causing by the natural drooping of saddle and self-weight; Neway utilizes special technology that makes a controlled crown capable of withstanding more weight. Upon installation, the deformation can be eased by controlling stress and deformation properly to achieve the targeted accuracy.



3 Separate Motor Mounts Control Heat and Thermal Growth

Our motor base is separate from the heat source, reducing the thermal growth efficiently. Additionally, Neway avoids backlash and partial deformation by utilizing high-end German reduction box on the transmission shaft these provide a solid structure and higher transmission accuracy with little or no growth or backlash.

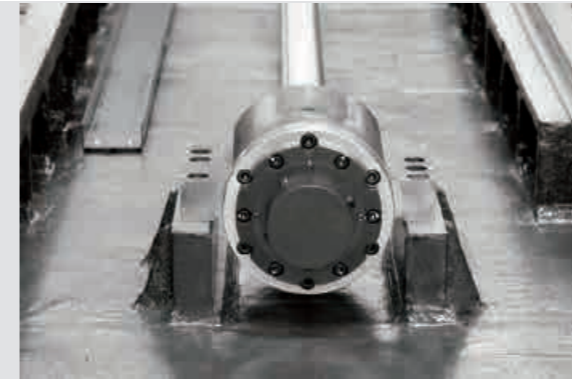

4 Ball Screws Are Pre-tensioned to Eliminate Backlash

Neway's pushing type Pre-tension structure is equipped with multi-bearings on both sides of the ball screws, absorbing the thermal deformation effectively while ensuring the pushing rigidity and accurate length of the ball screw.



5 Additional Support for Long Stroke Ball Screws

The auxiliary supporting system can effectively solve the problems of drooping and flexure of the ball screw, ensuring the transmission accuracy.

- 4m standard configuration is a set of the auxiliary supporting system;
- 6m span or more is 2 set of the auxiliary supporting system.



6 Hand Scraped and Qualified Surfaces

Hand Scraping all important joint faces achieve the highest assembly accuracy, increased rigidity, and better balance loads.



03 High Speed

High-Speed cutting can provide a higher quality surface finish of the work piece being milled. High-speed rapids and feed system provides higher efficiency of the workpiece being processed.



• High-Speed Spindle Options

Neway lets you decide the best spindle speed for your needs. Choose from 6K Gear, 8 - 15 K DDS, and even 18 K motorized spindle options are available.



• Built-in spindle



• Mechanical direct-drive spindle

• High Torque Transmission

Main transmission parts are designed with world-class brands, adopted a large transmission ratio, and double speed gear box which offers high speed and large spindle torque simultaneously.

• Efficient Carriage Components

Lighter weight design for carriage moving parts allows for faster and better high-speed interpolation processing.

• High-Speed Feed System

Neway machines use high-speed muting ball screws, coordinating with linearroller guideways. Each move quietly and stably without crawl or stick slip, improving the rapid traverse/feed speed of spindle dramatically.

• High-speed Vibration Control

Neway established strict inspection standards and accumulated long-term data. By testing the spindle at variety of speeds for vibration measurement to ensure high-speed spindle performance.

• Spindle Oil Cooling System

Neway High-speed type machining centers come equipped with spindle oil cooling system as standard equipment, it controls thermal deformation of spindle effectively, ensuring high-speed cutting ability.

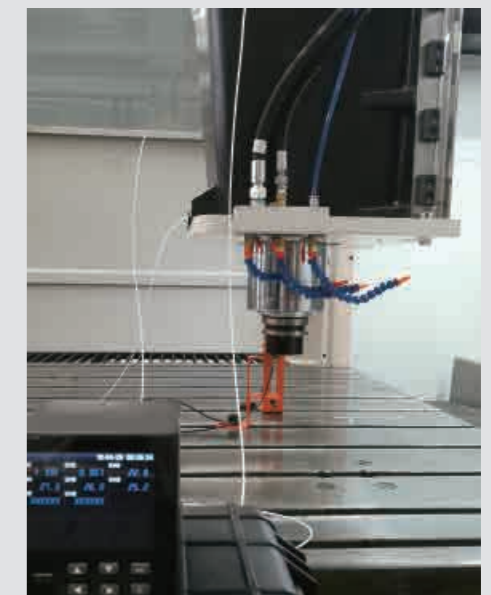

• High speed vibration test

04 Research & Development

Neway R&D consists of 7 separate R&D departments and employing 150 Full time engineers providing, 20+new products every year. 10+projects with core competencies focus, using PLM lifecycle management system to improve the efficiency.

Ongoing continuously improving quality refining projects:

- Static stiffness testing and research of machine tools
- Research on Vibration and Dynamic Stiffness of Machine Tools
- Research on Spectrum Analysis of Machine Tools
- Finite Element Analysis of complete Machine and Components
- Thermal deformation analysis of entire machine and components
- High-Speed Ball Screw Cooling System is Continuously improving.
- Research on Intelligent Development and Application of CNC Machine Tools
- High-pressure chip breaking test and application of the protective seal

1 PLM Lifecycle Management System

Neway uses the PLM lifecycle management system to improve researching efficiency.

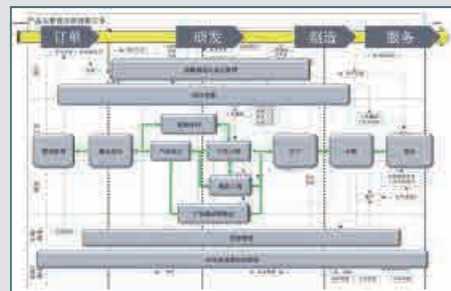

2 Finite Elements Analysis

All Major Components are designed using finite element analysis, the optimal layout of the structure, the use of high-quality cast iron materials provides high stability, good vibration damping.

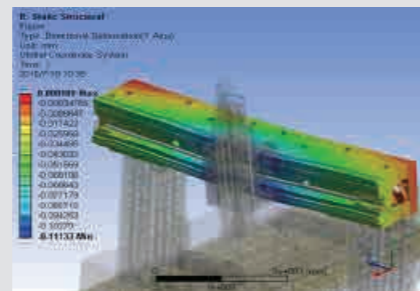

- Analysis of flexural deformation of beam

3 Modal Vibration Analysis

Improves the natural frequency and vibration resistance of machine tools through dynamic performance analysis testing and design enhancements built into the structure.

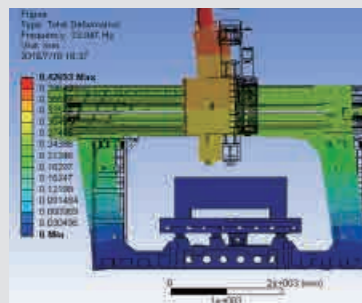

- Analysis of vibration characteristics of large gantry machine

4 Structural Thermal Analysis

Neway utilizes computerized thermal analysis to insure fit and structural fit and support of all spindle parts.

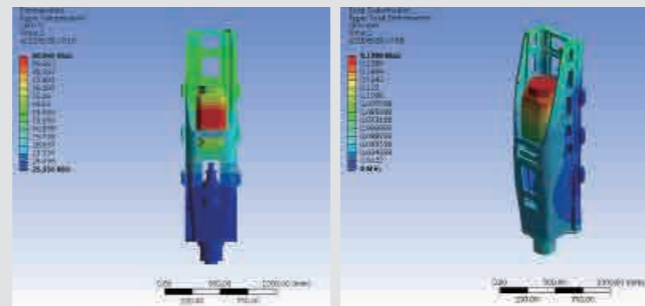

- Spindle thermal deformation

5 Temperature Rise Analysis

Neway analyzes temperature rise to improve the processing accuracy and durability of the machine tool.

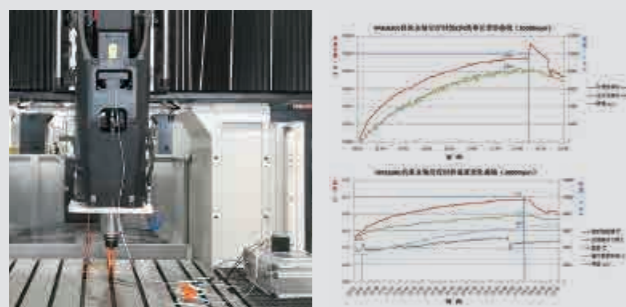

6 Vibration Analysis

The Vibration Analysis of the main drive system can provide an effective reference for structural improvement and process improvement and reduce the influence of vibration on machine life and machining precision.



05 Humanized Design

Based on ergonomics, customer feedback, careful design, continuous optimization, good operability, and convenient adjustment and maintenance.

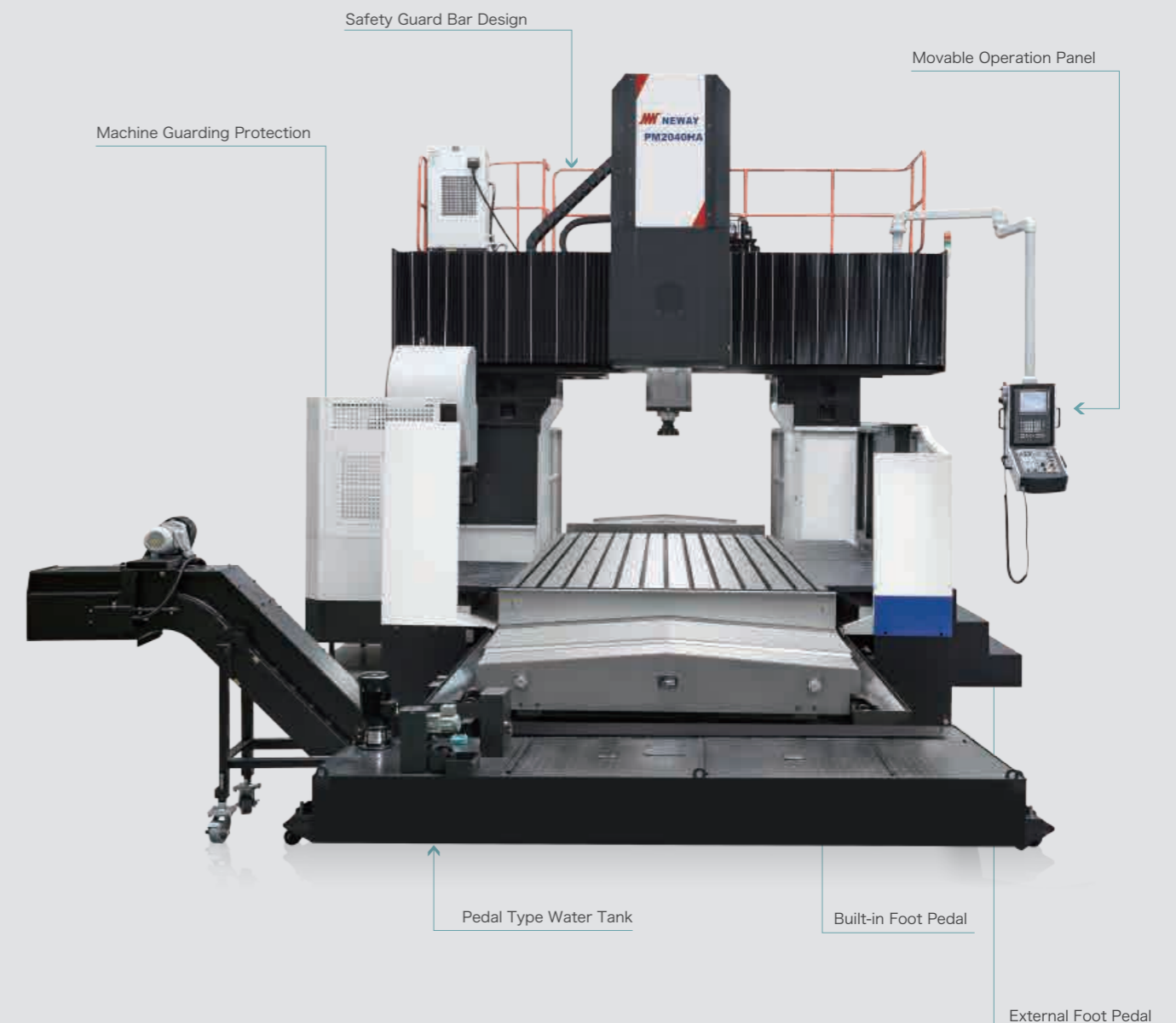

- **Moveable Operation Panel:** Pendant Rotates to the best position for smoother operation
- **Pedal Type Water Tank:** Easy to clean and used as a foot pedal
- **Built-in Foot Pedal:** Convenient up and down, save time
- **External Foot Pedal:** Easy to operate, safe and reliable
- **Safety Guard Bar Design:** Safe and reliable
- **Machine Guarding Protection:** Safe and reliable, to manage chips and coolant fluid from splashing (optional $\frac{3}{4}$ and even all-around roof top protection is available.)
- **Neway allows convenient custom operation in either direction for chip evacuation**

06 Industry Application

Complete product specifications, lots of choices, to ensure the application of machine to the World Market.



Industry	Ship
Material	16Mn/Q345A
Processing	Milling face, Boring hole, Drilling, Tapping
Machine Model	PM2030HA



Industry	Aviation
Material	Aluminum
Processing	Milling surface, Milling groove
Machine Model	PM1220V



Industry	Wind power
Material	45
Processing	Milling face, Milling hold, Milling outer circle, Milling groove, Drilling, Tapping
Machine Model	PM3080HA



Industry	Aviation
Material	Aluminum
Processing	Milling curve face, Milling groove
Machine Model	PM2040HA

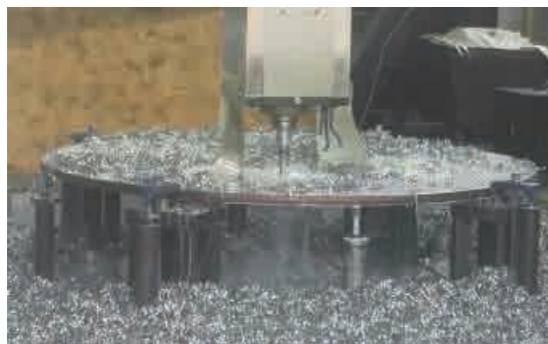

Industry	Nuclear power
Material	Q235A
Processing	Drilling
Machine Model	PM3040HA



Industry	Mould
Material	Die steel
Processing	Contour machining
Machine Model	PM2040HA



Industry	Marine engine
Material	HT250
Processing	Milling face, Boring, Drilling, Tapping, Reaming
Machine Model	PM2040HA

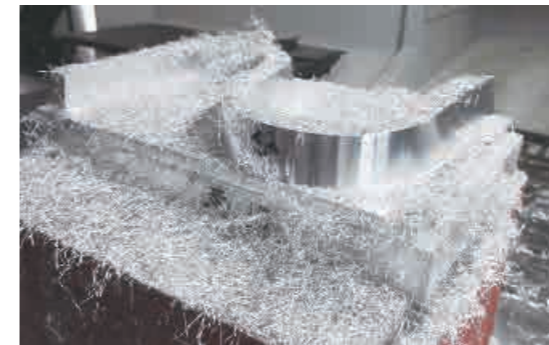

Industry	Aviation
Material	Aluminum
Processing	Milling face, Milling groove
Machine Model	PM2560U

PM-HA Series High-speed Gantry Machining Center

- This series adopts the fixed gantry frame and the worktable moving structure, with high rigidity, high precision, large torque, good dynamic characteristics and more.
- Bed, column, saddle, spindle box, worktable and other key parts all use resin sand molding, high-strength and high-quality cast iron to provide good stability and reduced harmonics.
- PM25 Series uses a 3- guide way design its anti-rotation torque capability is very strong. It can carry heavier work pieces on the table. The table will strongly resist vibration when heavy cutting. Workpiece can be provided excellent flatness when finishing.
- Well suited to Aerospace, Rail Transportation, Wind Power, Mold and many other diverse Industrial parts. Neway makes a great choice. By adding one or more of the optional heads, complete five face milling, drilling, boring, expansion, hinge, countersink, tapping, etc can be achieved easily.



Main parameters

		PM1220HA	PM1530HA	PM1830HA	PM2040HA	PM2560HA	PM3080HA
Worktable size	mm	1200×2000	1500×3000	1800×3000	2000×4000	2500×6000	3000×8000
Axis travel X/Y/Z	mm	2200×1200×800	3200×1900×800	3200×2700×800	4200×3200×1000	6200×3700×1000	8500×4200×1000
Spindle speed	mm	40-6000	40-6000	40-6000	40-6000	40-6000	40-6000
Max. output torque	N.m	788/1295	788/1295	525/647	770/910	770/910	770/910
Spindle motor power	kW	15/18.5	15/18.5	15/18.5	22/26	22/26	22/26

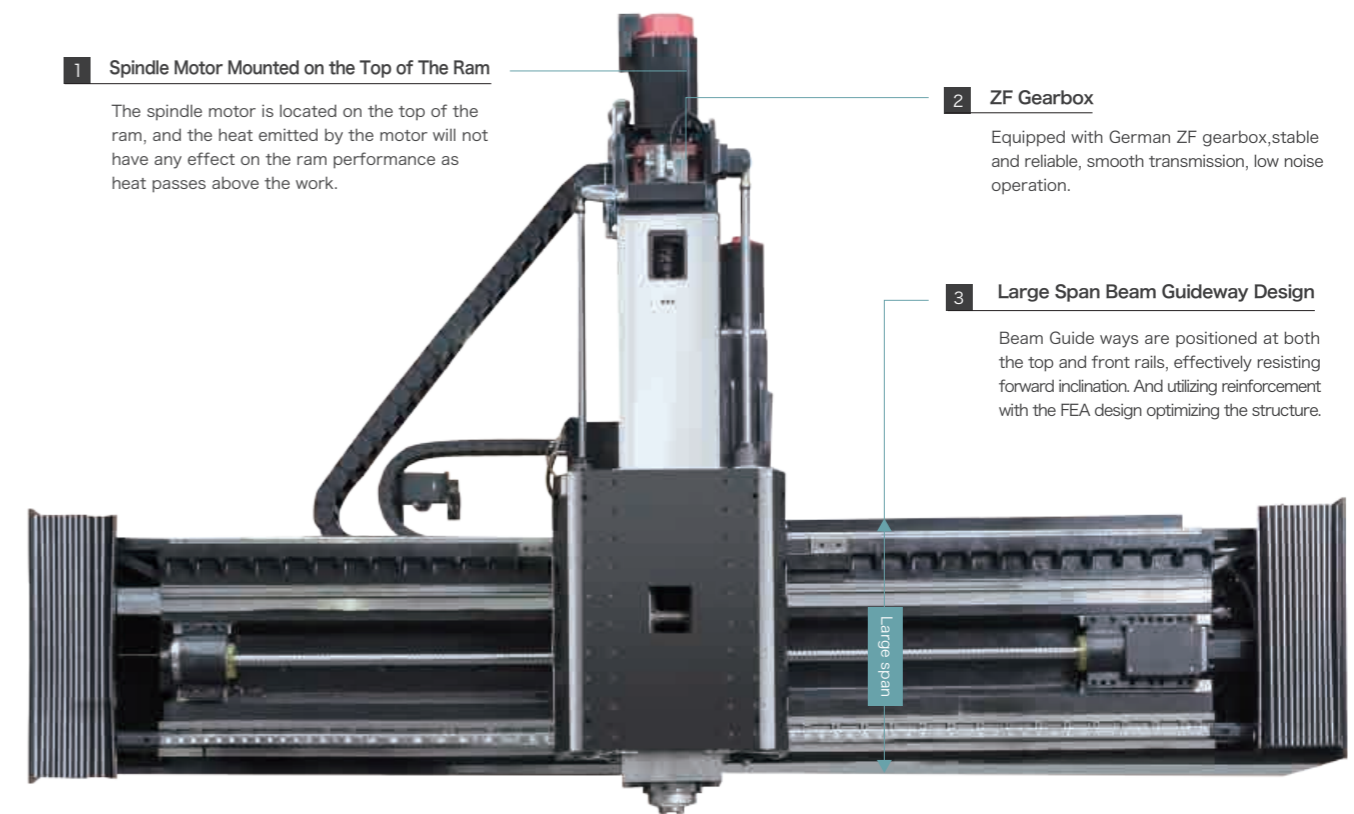

1 Spindle Motor Mounted on the Top of The Ram

The spindle motor is located on the top of the ram, and the heat emitted by the motor will not have any effect on the ram performance as heat passes above the work.

2 ZF Gearbox

Equipped with German ZF gearbox, stable and reliable, smooth transmission, low noise operation.

3 Large Span Beam Guideway Design

Beam Guide ways are positioned at both the top and front rails, effectively resisting forward inclination. And utilizing reinforcement with the FEA design optimizing the structure.

All structural components are analyzed for static and dynamic characteristics and response by finite element analysis (FEA) to ensure the machine with best performance in the dynamic and static state.

The use of roller-type linear guides increases rigidity and speed. Neway's layout of the guide rail span is optimal. The structure offers great rigidity with a one-piece bed that provides optimal strength, rigidity, and provides torsional flexural resistance that is superior to competitive machine builders.

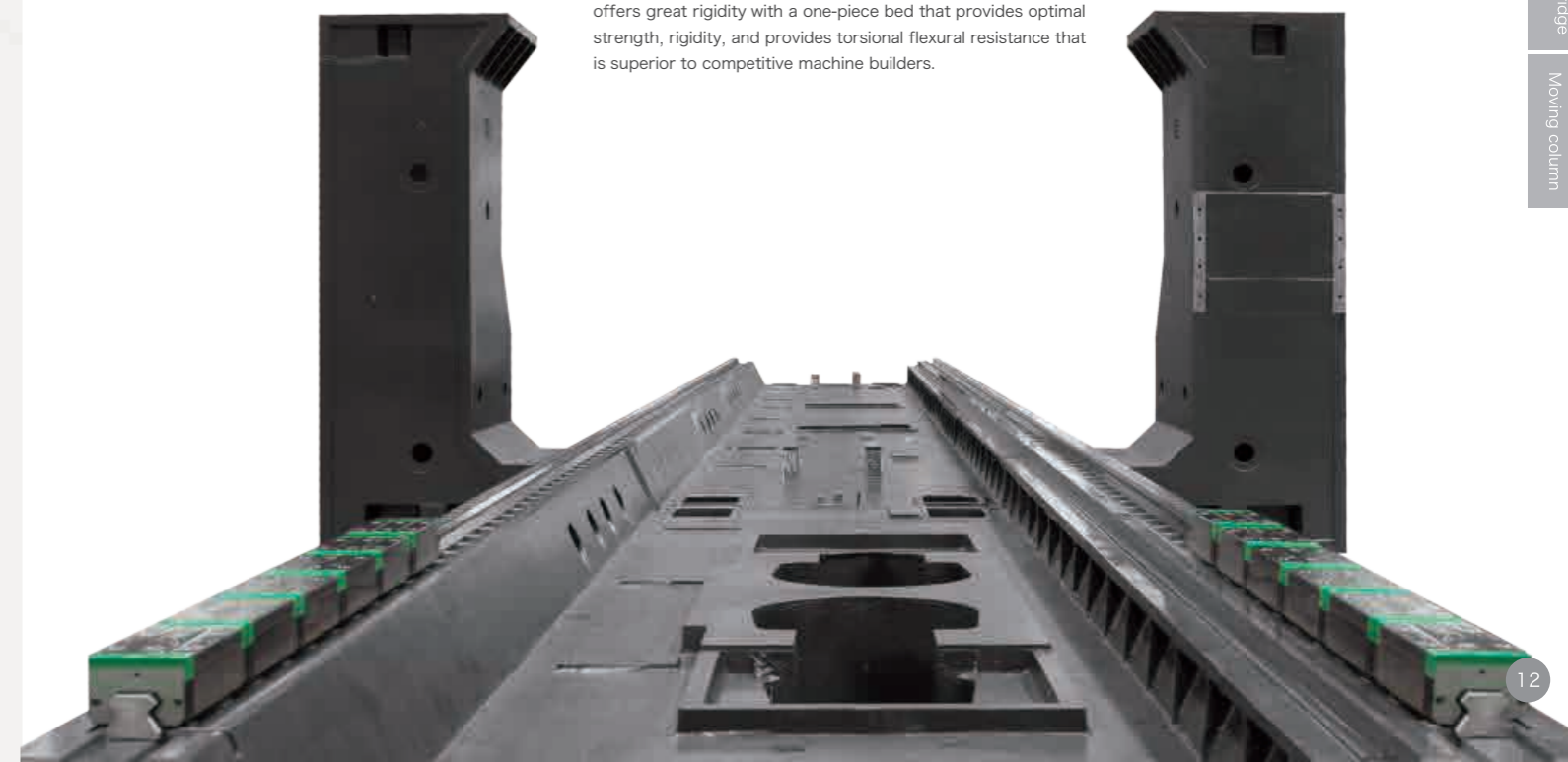

High-speed

High-speed Direct Drive Spindle

High-speed Built-in Spindle

High-speed 5 Axis

High-speed 5 Axis Bridge Moving Cross-rail

Moving column



• All-inclusive Square Ram

Box-in box square RAM design, 8 sliding guide way rails around the ram. The ram provides anti deflection and superior cutting resistance ability.

• High Torque Spindle

Imported world-class spindle units with proven strong chip-cutting ability, high-speed, and maximum torque output 770/910N.m of torque.



• Saddle Design

The sliding saddle is very well supported ensuring the highest dynamic performance and static rigidity, providing an extremely solid foundation for precision machining.

• Y Axis Guide Way Stepped structure

Y-axis Guide way with step configuration provides the shortest distance between lower guide way and spindle center design this combined with heavy roller slide provides effective resistance to turning torque during machining.

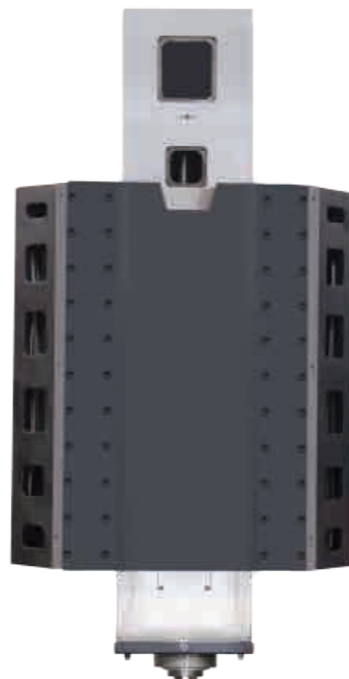

Note: the features above are suitable for some machines

Spindle Power Torque Diagram

External Dimensions

(Unit: mm)

PM12/15HA Series

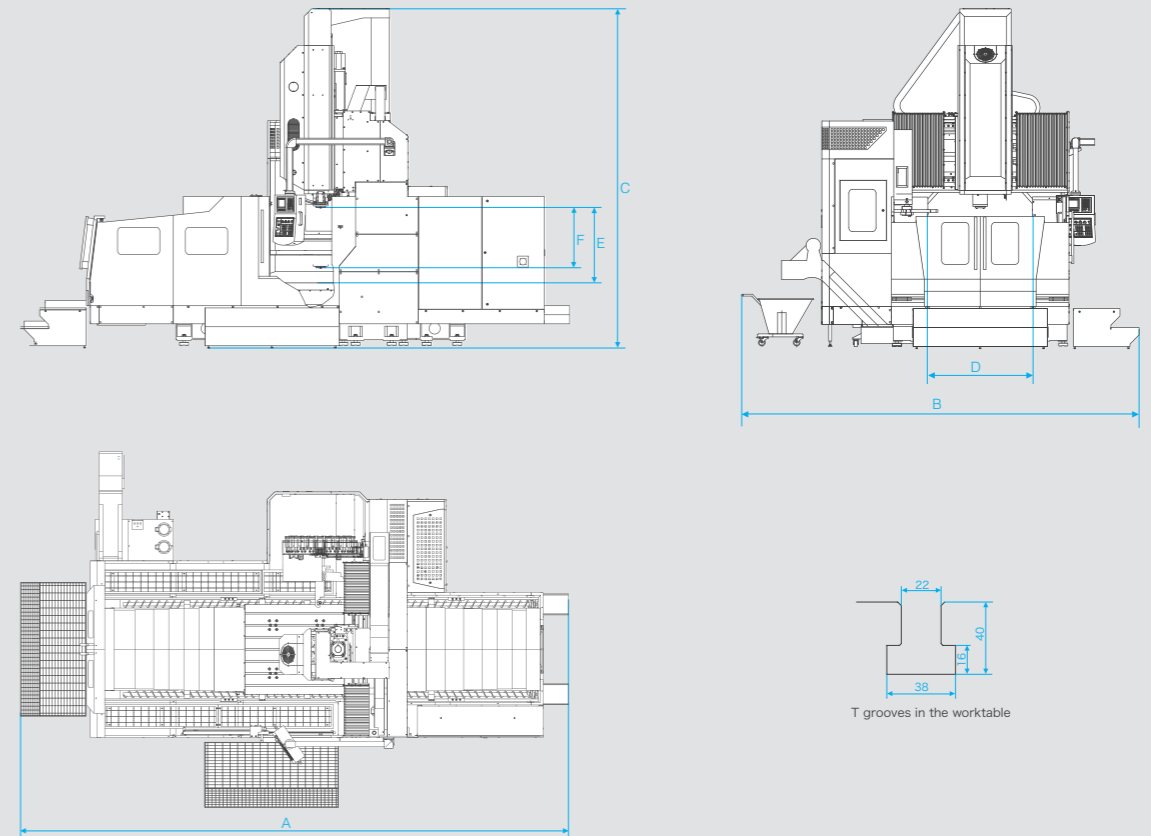
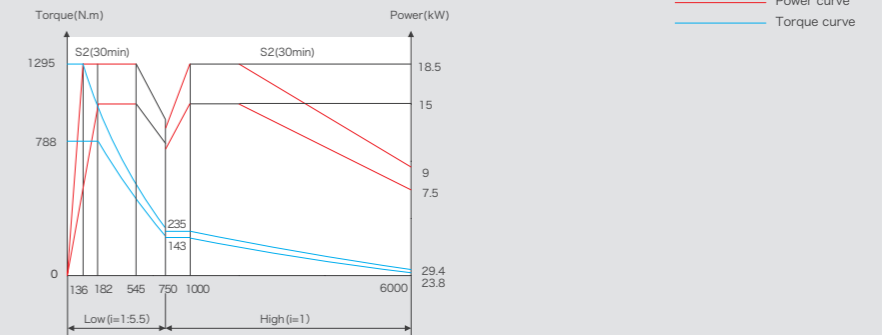

Type	A	B	C	D	E	F
	Length	Width	High	Column span	Spindle terminal to worktable	Z axis travel
PM1220HA	7300	5500	4500	1400	1000	800
PM1230HA	9540					
PM1240HA	11800					
PM1520HA	7600	5900	4550	1800	1000	800
PM1530HA	9700					

High-speed

High-speed Direct Drive Spindle

High-speed Built-in Spindle

High-speed 5 Axis

High-speed 5 Axis Bridge Moving Cross-rail

Moving column

Spindle Power Torque Diagram External Dimensions

(Unit: mm)

PM16/18HA Series

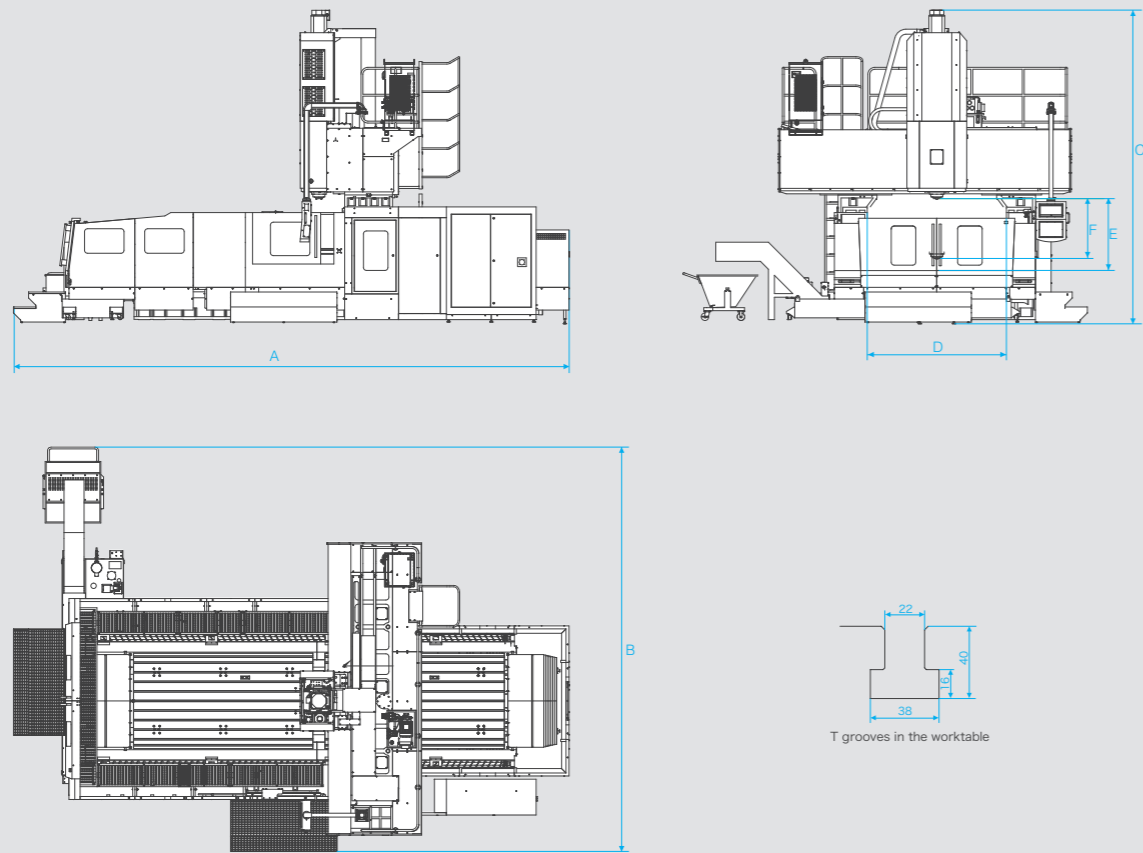
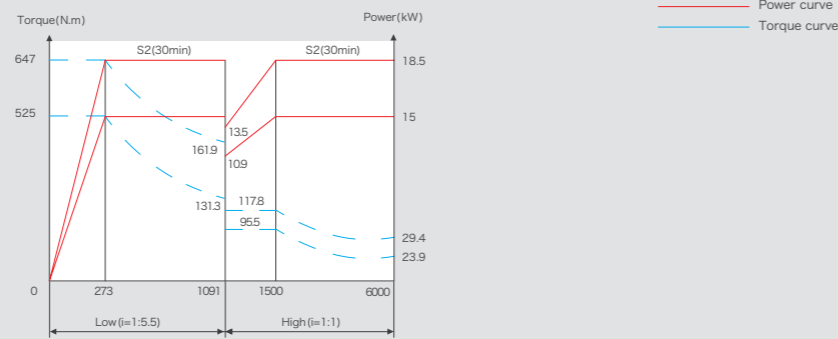

Type	A Length	B Width	C High	D Column span	E Spindle terminal to worktable	F Z axis travel
PM1630HA	9500	6000	5050[5250]	1800[2300]	1000[1200]	800[1000]
PM1830HA	9500	6500	5250	2300	1200	1000
PM1840HA	11500					

Spindle Power Torque Diagram External Dimensions

(Unit: mm)

PM20/25/30HA Series

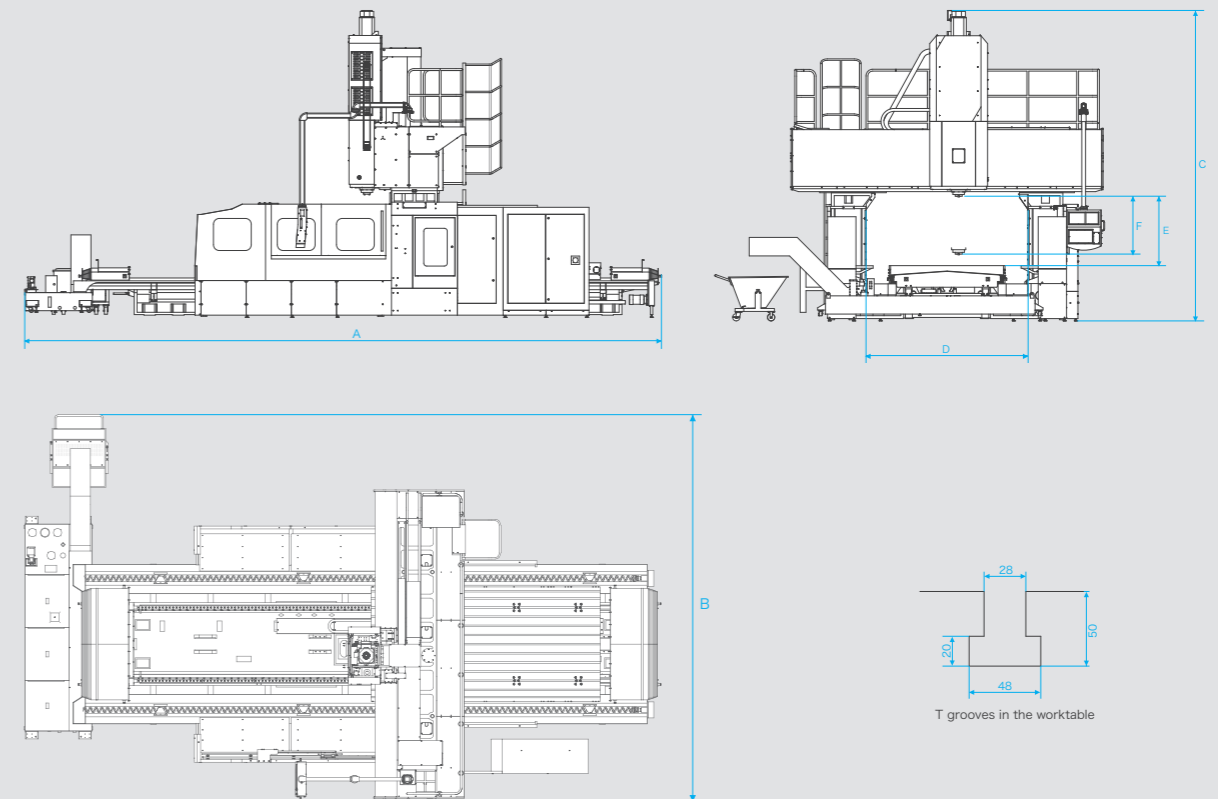
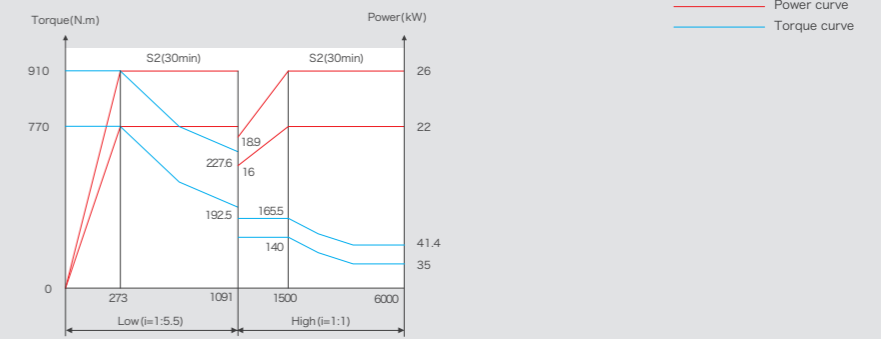

Type	A Length	B Width	C High	D Column span	E Spindle terminal to worktable	F Z axis travel
PM2030HA	9000	6500	5400	2800[3200]	1200[1000][1500]	1000[800][1250]
PM2040HA	11000					
PM2060HA	15000					
PM2080HA	20000					
PM2530HA	9000	7600	5500	3300	1200[1500]	1000[1250]
PM2540HA	11000					
PM2560HA	15400					
PM2580HA	20000					
PM25100HA	25500	7900	5500	3800	1200[1500]	1000[1250]
PM3040HA	12000					
PM3060HA	15400					
PM3080HA	20000					
PM30100HA	25500					

High-speed
High-speed Direct Drive Spindle
High-speed Built-in Spindle
High-speed 5 Axis
High-speed 5 Axis Bridge Moving Cross-rail
Moving column

Item	Unit	PM1220HA	PM1230HA	PM1240HA	PM1520HA	PM1530HA	PM1630HA	PM1830HA	PM1840HA	PM2030HA	PM2040HA	PM2060HA	PM2080HA	
Worktable	Worktable width	mm	1200			1500		1600	1800			2000		
	Worktable length	mm	2000	3000	1200	2000	3000	3000	4000	3000	4000	6000	8000	
	Table load	kg	3500	5500	3000	6000	7000	10000	10000	12000	16000	20000	26000	28000
Capacity	Worktable travel (X axis)	mm	2200	3200	5500	2200	3200	3200	3200	4200	3200	4200	6200	8500
	Carriage travel (Y axis)	mm	1200[1500][1700]			1900		2100[2700]	2700			3200		
	Ram travel (Z axis)	mm	800			800		800 [1000]	800 [1000]			1000 [800] [1250]		
	Spindle terminal to worktable	mm	200~1000			200~1000		200~1000 [200~1200]	200~1000 [200~1200]			200~1200 [200~1000] [250~1500]		
	Column span	mm	1400[1600]			1800		1800[2300]	2300			2800 [3200]		
Spindle	Tool shank size	-	BT50			BT50		BT50	BT50			BT50		
	Spindle speed	r/min	40~6000			40~6000		40~6000	40~6000			40~6000 [Z axis1250: 40~4500]		
	Max. output torque	N.m	788/1295			788/1295		525/647 [770/910]	525/647 [770/910]			770/910		
	Spindle motor power	kW	15/18.5			15/18.5		15/18.5 [22/26]	15/18.5 [22/26]			22/26		
	Ram section	mm	400×320			400×320		400×400	400×400			400×400 [Z axis1250: 420×420]		
Rapid travel	X/Y/Z axis rapid trave	m/min	24/24/15	15/24/15	12/24/15	12/24/15	12/24/15	20/18/15	20/18/15	15/18/15	15/15/12	15/15/12	12/15/12	10/15/10
ATC	Tool position	-	24 [32/40/60]			24 [32/40/60]		[24/32/40/60]	[24/32/40/60]			[24/32/40/60]		
	Max. tool diam./length/weight	mm/mm/kg	Φ110/350/15			Φ110/350/15		Φ105/350/15	Φ105/350/15			Φ105/350/15		
	Max. tool diameter (empty neighbor)	mm	Φ200			Φ200		Φ200	Φ200			Φ200		
Accuracy GB/T17421.2-2016 ISO 230-2:2006	X axis (positioning/repeatability)	mm	0.012/0.008	0.017/0.012	0.022/0.016	0.012/0.008	0.017/0.012	0.020/0.012	0.020/0.012	0.025/0.016	0.020/0.012	0.025/0.016	0.035/0.024	0.045/0.032
	Y axis (positioning/repeatability)	mm	0.012/0.008			0.014/0.009		0.016/0.010	0.016/0.010			0.020/0.012		
	Z axis (positioning/repeatability)	mm	0.012/0.008			0.014/0.009		0.016/0.010	0.016/0.010			0.016/0.010 [Z axis1250: 0.020/0.012]		
CNC system	-	NEWAY FANUC [SIEMENS]					NEWAY FANUC [SIEMENS]			NEWAY FANUC [SIEMENS]				
Machine weight	kg	19000	23000	26000	21000	25000	29000	30000	35000	41000	45000	55000	65000	

PM12/15HA Standard configuration:

ZF retarder, spindle and retarder cooling system, long terminal spindle, spindle air curtain protection system, ram balance system, X/Y/Z axis direct connection (no belt), disc-type tool magazine with 24 tool positions, full protection (including internal pedal), automatic chip conveying system, LED lights and caution lights, handheld operation unit, Centralized lubrication system, stainless-steel telescopic shield bed, anchor bolts and horizontal adjustment components, air and coolant tool cooling system, air gun, cutting compound oil-water separation equipment.

PM12/15HA Options:

Milling head, DIN/CAT/ISO blind rivet and shank, coolant through spindle, column heighten increase, full protection, tool magazine 32/40/60T, Rotary table, grating ruler, oil-mist collection equipment, tool detection device, workpiece measuring device, water gun, CNC system with special functions.

PM16/18HA Standard configuration:

ZF retarder, full-protection square ram, spindle and retarder cooling system, short terminal spindle, spindle air curtain protection system, Ram balance system, X/Y/Z axis direct connection (no belt), full protection (including internal pedal), beam handrail and stairs, automatic chip conveying system, LED lights and caution lights, Handheld Operation unit, electric cabinet air-conditioning, centralized lubrication system, stainless-steel telescopic shield bed, anchor bolts and horizontal adjustment components, air and coolant tool cooling system, air gun, cutting compound oil-water separation equipment.

PM16/18HA Options:

Milling head, DIN/CAT/ISO blind rivet and shank, long terminal spindle, coolant through spindle, column height increase, tool magazine 32/40/60T, Vertical and horizontal tool magazine 32/40/60T, rotary table, grating ruler, oil-mist collection device, tool detection device, workpiece measuring device, water gun, CNC system with special functions.

High-speed

High-speed Direct Drive Spindle

High-speed Built-in Spindle

High-speed 5 Axis

High-speed 5 Axis Bridge Moving Cross-rail

Moving column

Item	Unit	PM2530HA	PM2540HA	PM2560HA	PM2580HA	PM25100HA	PM3040HA	PM3060HA	PM3080HA	PM30100HA	
Worktable	Worktable width	mm	2500				3000				
	Worktable length	mm	3000	4000	6000	8000	10000	4000	6000	8000	10000
	Table load	kg	18000	22000	30000	35000	40000	25000	35000	40000	45000
Capacity	Worktable travel (X axis)	mm	3200	4200	6200	8500	10500	4200	6200	8500	10500
	Carriage travel (Y axis)	mm	3200		3700 [4200]			4200 [4600]			
	Ram travel (Z axis)	mm	1000 [1250]				1000 [1250]				
	Spindle terminal to worktable	mm	200~1200 [250~1500]				140-1140 [190-1440]	200~1200 [250~1500]			140-1140 [190-1440]
	Column span	mm	2800 [3200]		3300 [3800]			3800 [4200]			
Spindle	Tool shank size	-	BT50				BT50				
	Spindle speed	r/min	40~6000 [Z axis1250: 40~4500]				40~6000 [Z axis1250: 40~4500]				
	Max. output torque	N.m	770/910				770/910				
	Spindle motor power	kW	22/26				22/26				
	Ram section	mm	400×400 [Z axis1250: 420×420]				400×400 [Z axis1250: 420×420]				
Rapid travel	X/Y/Z axis rapid trave	m/min	12/12/12	12/12/12	12/12/12	10/12/12	8/12/12	12/12/12	12/12/12	10/12/12	8/12/12
ATC	Tool position	-	[24/32/40/60]				[24/32/40/60]				
	Max. tool diam./length/weight	mm/mm/kg	Φ105/350/15				Φ105/350/15				
	Max. tool diameter (empty neighbor)	mm	Φ200				Φ200				
Accuracy GB/T17421.2-2016 ISO 230-2:2006	X axis (positioning/repeatability)	mm	0.020/0.012	0.025/0.016	0.035/0.024	0.045/0.032	0.055/0.040	0.025/0.016	0.035/0.024	0.045/0.032	0.055/0.040
	Y axis (positioning/repeatability)	mm	0.025/0.016				0.030/0.020				
	Z axis (positioning/repeatability)	mm	0.016/0.010 [Z axis1250: 0.020/0.012]				0.016/0.010 [axis1250: 0.020/0.012]				
CNC system	-	NEWAY FANUC [SIEMENS]				NEWAY FANUC [SIEMENS]					
Machine weight	kg	45000	50000	65000	85000	95000	55000	70000	90000	100000	

PM20/25/30HA Standard configuration:

ZF retarder, full-protection square ram, spindle and retarder cooling system, short terminal spindle, spindle air curtain protection system, Ram balance system, X/Y/Z axis direct connection (no belt), processing area protection, beam handrail and stairs, automatic chip conveying system, LED lights and caution lights, handheld operation unit, electric cabinet air-conditioning, centralized lubrication system, stainless-steel telescopic shield bed, anchor bolts and horizontal adjustment components, air and coolant tool cooling system, air gun, cutting compound oil-water separation equipment.

PM20/25/30HA Options:

Milling head, DIN/CAT/ISO blind rivet and shank, long terminal spindle, coolant through spindle, column span increase, column height increase, tool magazine 32/40/60T, Vertical and horizontal tool magazine 32/40/60T, rotary table, grating ruler, full protection, tool detection device, Workpiece measuring device, water gun, CNC system with special functions.

[] Option

PM-L Series High-speed Direct Drive Spindle Gantry Machining Center

- This series machine directly connects the high-speed spindle through spindle motor; Spindle speeds up to 15,000rpm;
- The mechanical spindle is well proven and reliable, easy maintenance, durable;
- The lightweight design of sliding saddle and RAM for faster-moving speed;
- Suitable for machining in the fields of mold finishing, aluminum processing, auto parts, aerospace, engineering machinery, etc.

1 Hi-Speed Direct Drive Spindle (DDS)

Hi-speed direct coupling spindle adopts advanced assembly technology and effective test method to ensure the minimum vibration of the spindle during high-speed motion, and improved machining precision and greatly improved work piece surface's quality.

2 Top Layout of Beam Guide Way

The guideway on the beam is arranged on the top of the beam, pulling the distance of the rail, increasing the rigidity of the saddle support and increasing the anti-roll ability of the spindle box.

3 Integral Design For Saddle, Motor Base and Cylinder Support

Integrated design for the saddle and motor base, cylinder support provides stronger support and overall rigidity. Neway reduced the length of the hydraulic line, the accumulator was placed on the saddle, and an unclamping cylinder was arranged on the top of the ram which reduced the pressure loss making the actuator more responsive.

4 Z-axis Liner Guide Way, Auto Balance System

Z-axis roller guide way, coupled with auto balance system makes this model suitable for Z axis frequently and rapidly moving, reacting more accurately and quickly.



High-speed

High-speed Direct Drive Spindle

High-speed Built-in Spindle

High-speed 5 Axis

High-speed 5 Axis Bridge Moving Cross-rail

Moving column

Spindle Power Torque Diagram External Dimensions

(Unit: mm)

PM13/15L Series

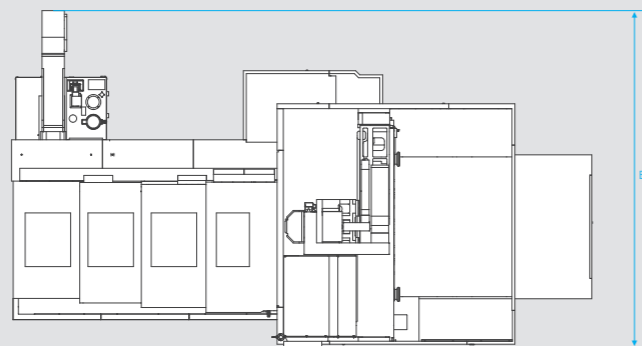
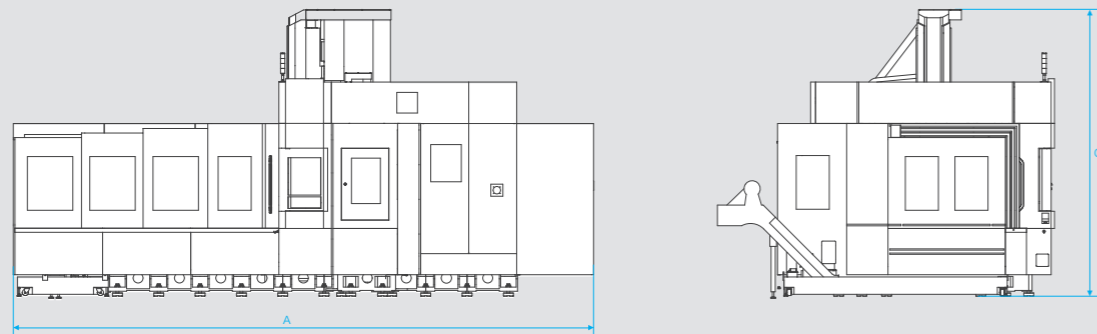
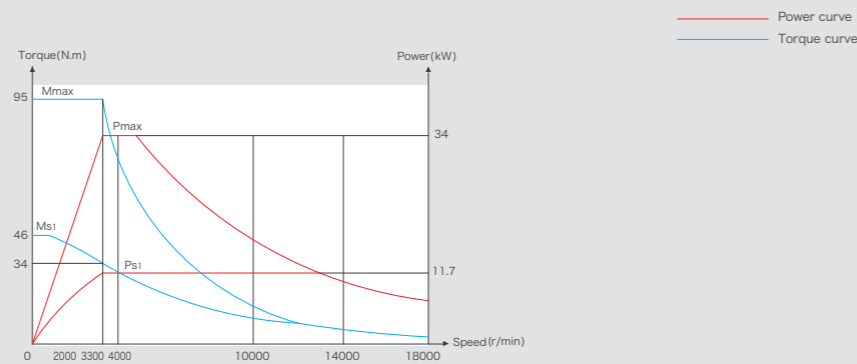

Type	A	B	C	D	E	F
	Length	Width	High	Column span	Spindle terminal to worktable	Z axis travel
PM0813L	3282	4180	3480	1400	150-850	700
PM1320L	6020	3880				
PM1325L	7020					
PM1330L	8020					
PM1520L	6020	4080		1600		
PM1525L	7020					
PM1530L	8020					

Spindle Power Torque Diagram External Dimensions

(Unit: mm)

PM18L Series

PM20L Series

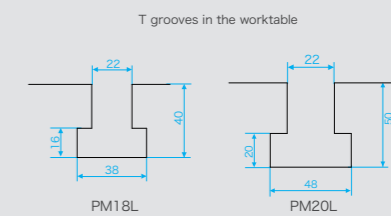
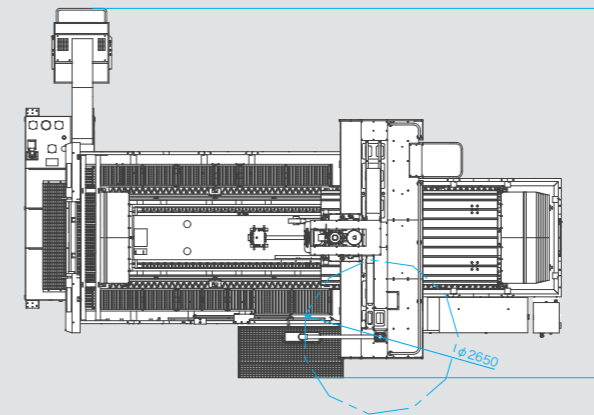
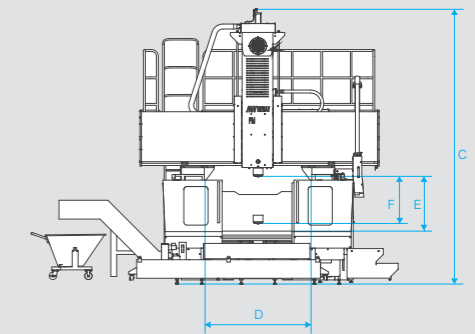
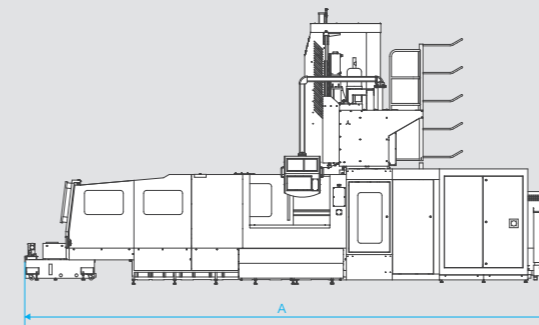
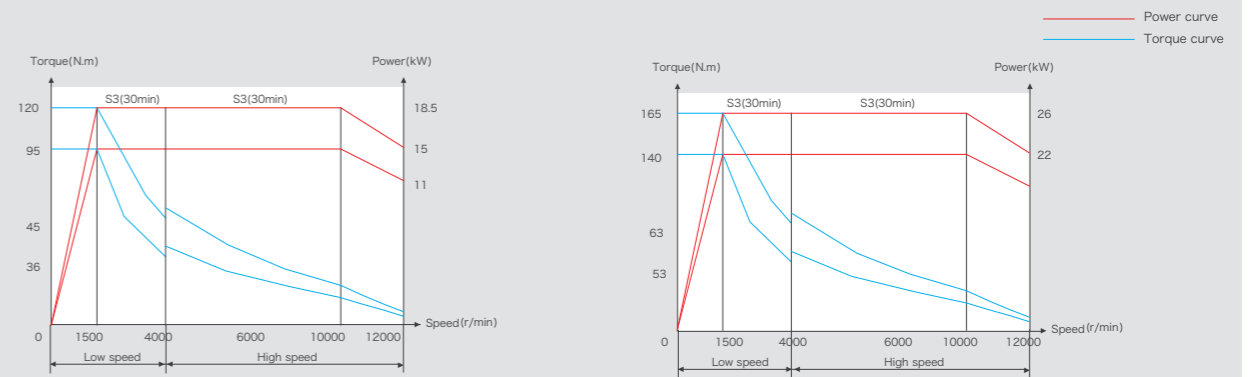

Type	A	B	C	D	E	F
	Length	Width	High	Column span	Spindle terminal to worktable	Z axis travel
PM1630L	9100	5750	4700	1800	930	800
PM1830L	9100	6250		2300		
PM1840L	11100					
PM2030L	9100	6500	5000	2800	1130	1000
PM2040L	11100					
PM2060L	15100					

High-speed

High-speed Direct Drive Spindle

High-speed Built-in Spindle

High-speed 5 Axis

High-speed 5 Axis Bridge Moving Cross-rail

Moving column

Item	Unit	PM0813L	PM1320L	PM1325L	PM1330L	PM1520L	PM1525L	PM1530L	
Worktable	Worktable width	mm	1300			1500			
	Worktable length	mm	900	2100	2600	3100	2100	2600	3100
	Table load	kg	1500	3500	6000	8000	6000	8000	10000
Capacity	Worktable travel (X axis)	mm	800	2200	2700	3200	2200	2700	3200
	Carriage travel (Y axis)	mm	1300			1500			
	Ram travel (Z axis)	mm	700			700			
	Spindle terminal to worktable	mm	150-850			150-850			
	Column span	mm	1400			1600			
Spindle	Tool shank size	-	BT40			BT40			
	Spindle speed	r/min	15000			15000			
	Max. output torque	N.m	34/46			34/46			
	Spindle motor power	kW	11.7/15.8			11.7/15.8			
	Ram section	mm	350×350			350×350			
Rapid travel	X/Y/Z axis rapid trave	m/min	24/24/24	18/24/24			20/24/24		
ATC	Tool position	-	[24/32]			[24/32]			
	Max. tool diam./length/weight	mm/mm/kg	φ80/250/8			φ80/250/8			
Accuracy GB/T17421.2-2016 ISO 230-2:2006	X axis (positioning/repeatability)	mm	0.012/0.008	0.016/0.010	0.018/0.010	0.020/0.012	0.016/0.010	0.018/0.010	0.020/0.012
	Y axis (positioning/repeatability)	mm	0.016/0.010			0.016/0.010			
	Z axis (positioning/repeatability)	mm	0.016/0.010			0.016/0.010			
CNC system	-	SIEMENS 828D [NEWAY FANUC]							
Machine weight	kg	12000	18000	20000	22000	20000	22000	25000	

Standard configuration:

High-speed direct drive mechanical spindle, spindle cooling system, long terminal spindle, spindle air curtain protection system, X/Y/Z axis roller guideway, X/Y/Z axis direct connection (no belt), full protection, automatic chip conveying system, LED lights and caution lights, handheld operation unit, centralized lubrication system, stainless-steel telescopic shield bed, anchor bolts and horizontal adjustment components, air and coolant tool cooling system, air gun, cutting compound oil-water, separation device.

Options:

Grating ruler, DIN/CAT/ISO blind rivet and shank, tool magazine 24/32T, rotary worktable, tool detection device, workpiece measuring device, water gun, CNC system with special functions.

Item	Unit	PM1820L	PM1830L	PM1840L	PM2030L	PM2040L	PM2060L	
Worktable	Worktable width	mm	1800			2000		
	Worktable length	mm	2000	3000	4000	3000	4000	6000
	Table load	kg	8000	10000	12000	16000	20000	26000
Capacity	Worktable travel (X axis)	mm	2200	3200	4200	3200	4200	6200
	Carriage travel (Y axis)	mm	2700			3200		
	Ram travel (Z axis)	mm	800 [1000]			1000		
	Spindle terminal to worktable	mm	130~930 [130~1130]			130~1130		
	Column span	mm	2300			2800		
Spindle	Tool shank size	-	BT50 [BT40]			BT50 [BT40]		
	Spindle speed	r/min	100~12000 [BT40:15000]			100~10000 [BT40:15000]		
	Max. output torque	N.m	95/118			140/165 [BT40:95/118]		
	Spindle motor power	kW	15/18.5			22/26 [BT40:15/18.5]		
	Ram section	mm	450×400			450×400		
Rapid travel	X/Y/Z axis rapid trave	m/min	20/18/20	20/18/20	15/18/20	15/15/15	15/15/15	12/15/15
ATC	Tool position	-	[24/32/40/60]			[24/32/40/60]		
	Max. tool diam./length/weight	mm/mm/kg	φ105/350/15			φ105/350/15		
	Max. tool diameter (empty neighbor)	mm	φ200			φ200		
Accuracy GB/T17421.2-2016 ISO 230-2:2006	X axis (positioning/repeatability)	mm	0.016/0.010	0.020/0.012	0.025/0.016	0.020/0.012	0.025/0.016	0.035/0.024
	Y axis (positioning/repeatability)	mm	0.016/0.010			0.020/0.012		
	Z axis (positioning/repeatability)	mm	0.016/0.010			0.016/0.010		
CNC system	-	NEWAY FANUC(SIEMENS)						
Machine weight	kg	23000	25000	28000	35000	40000	50000	

Standard configuration:

High-speed direct drive mechanical spindle, spindle cooling system, long terminal spindle, spindle air curtain protection system, Ram balance system, X/Y/Z axis roller guideway, X/Y/Z axis direct connection (no belt), full protection (PM18L), beam handrail and stairs, automatic chip conveying system, LED lights and caution lights, handheld operation unit, Electric cabinet air-conditioning, centralized lubrication system, stainless-steel telescopic shield bed, anchor bolts and horizontal adjustment components, air and coolant tool cooling system, air gun, cutting compound oil-water separation device.

Options:

Different torque and spindle speed, grating ruler, DIN/CAT/ISO blind rivet and shank, tool magazine 32/40/60T, column height increase, rotary worktable, full protection (PM18L), full protection (PM20L), tool detection device, workpiece measuring device, water gun, CNC system with special functions.

High-speed

High-speed Direct Drive Spindle

High-speed Built-in Spindle

High-speed 5 Axis

High-speed 5 Axis Bridge Moving Cross-rail

Moving column

[]Option

PM-V Series High-Speed Built-in Spindle Gantry Machining Center

- This type of machine adopts 15,000 rpm, or above motorized spindle, the main drive chain shortens to zero which makes the machine more stable and accuracy in working and improving the quality of the workpiece;
- The spindle and motor linked together, the motor is set in the middle of the bearings, rigid structure, improving spindle's strength and cutting capabilities;
- Less vibration offers a more stable process, with higher accuracy and better finish flatness when processing parts;
- Adopts full spindle protection design, air curtain avoids chip splash;
- Suitable for aerospace, auto industry, rail transit, wind power, aluminum alloy, mold, etc.



Main parameters

		PM1220V	PM1530V	PM1830V	PM2040V
Worktable size	mm	1200×2000	1500×3000	1800×3000	2000×4000
Axis travel X/Y/Z	mm	2200×1200×800	3200×1900×800	2200×2700×800	4200×3200×1000
Spindle speed	mm	100-18000	100-18000	100-18000	100-18000
Max. output torque	N.m	51.7/107	51.7/107	88.3/159	88.3/159
Spindle motor power	kW	13/18.5	13/18.5	18.5/25	18.5/25

Spindle Power Torque Diagram

External Dimensions

(Unit: mm)

PM12/15V Series

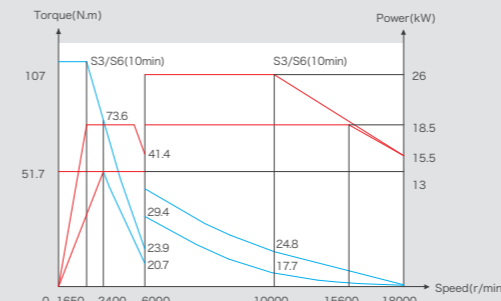

PM18/20V Series

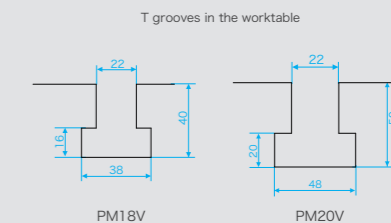
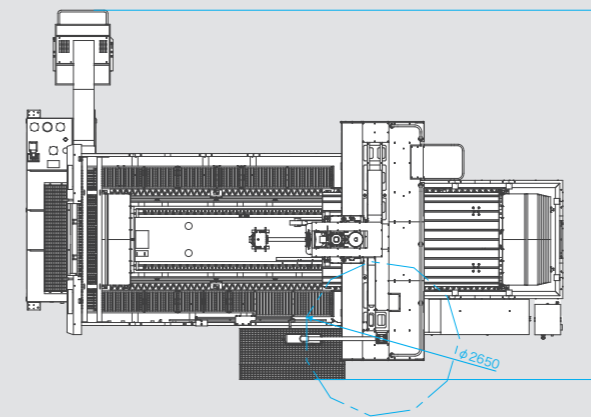
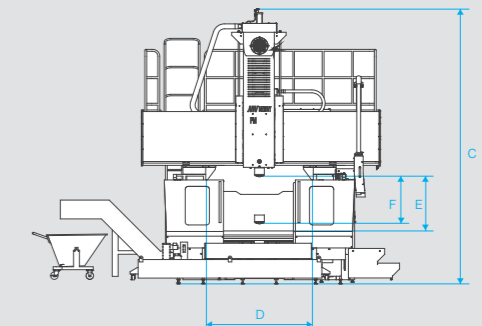
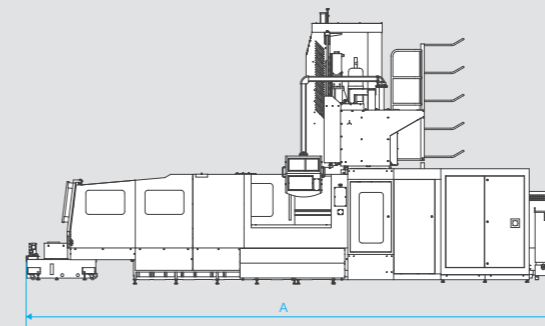
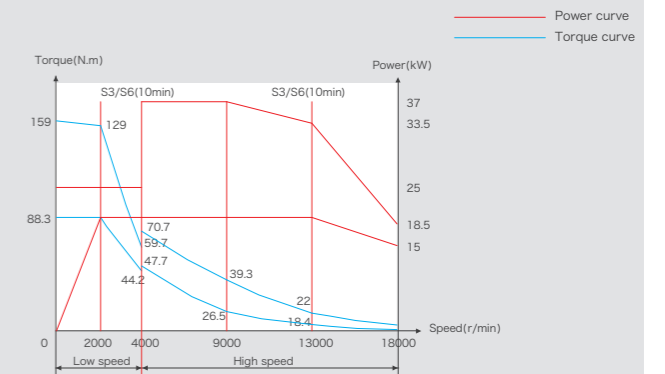

Type	A Length	B Width	C High	D Column span	E Spindle terminal to worktable	F Z axis travel
PM1220V	7300	5500	4300	1400	1000	800
PM1230V	9540					
PM1240V	11800					
PM1520V	7600					
PM1530V	9700	6250	4700	2300	1200	1000
PM1830V	9100					
PM1840V	11100					
PM2030V	9100	6500	5000	2800	1200	1000
PM2040V	1110					
PM2060V	15100					

High-speed
High-speed Direct Drive Spindle
High-speed Built-in Spindle
High-speed 5 Axis
High-speed 5 Axis Bridge Moving Cross-rail
Moving column

Item		Unit	PM1220V	PM1230V	PM1240V	PM1520V	PM1530V	PM1830V	PM1840V	PM2030V	PM2040V	PM2060V	
Worktable	Worktable width	mm	1200			1500		1800			2000		
	Worktable length	mm	2000	3000	4000	2000	3000	3000	4000	3000	4000	6000	
	Table load	kg	3500	5500	7000	6000	7000	10000	12000	16000	20000	26000	
Capacity	Worktable travel (X axis)	mm	2200	3200	4200	2200	3200	3200	4200	3200	4200	6200	
	Carriage travel (Y axis)	mm	1200 [1500]			1900		2700			3200		
	Ram travel (Z axis)	mm	800			800		800 [1000]			1000		
	Spindle terminal to worktable	mm	110~910			110~910		200~1000 [200~1200]			200~1200		
	Column span	mm	1400			1800		2300			2800		
Spindle	Tool shank size	-	HSK-A63			HSK-A63		HSK-A63			HSK-A63		
	Spindle speed	r/min	100~18000			100~18000		100~18000			100~18000		
	Max. output torque	N.m	51.7/107			51.7/107		88.3/159			88.3/159		
	Spindle motor power	kW	13/18.5			13/18.5		18.5/25			18.5/25		
	Ram section	mm	400×320			400×320		450×400			450×400		
Rapid travel	X/Y/Z axis rapid trave	m/min	30/30/24	24/30/24	18/30/24	24/24/24	15/24/15	20/18/20	15/18/20	15/15/15	15/15/15	12/15/15	
ATC	Tool position	-	24 [32/40/60]			24 [32/40/60]		[24/32/40/60]			[24/32/40/60]		
	Max. tool diam./length/weight	mm/mm/kg	Φ80/300/8			Φ80/300/8		Φ80/300/8			Φ80/300/8		
	Max. tool diameter (empty neighbor)	mm	Φ150			Φ150		Φ150			Φ150		
Accuracy GB/T17421.2-2016 ISO 230-2:2006	X axis (positioning/repeatability)	mm	0.012/0.008	0.017/0.012	0.022/0.016	0.012/0.008	0.017/0.012	0.016/0.010	0.025/0.016	0.020/0.012	0.025/0.016	0.035/0.024	
	Y axis (positioning/repeatability)	mm	0.012/0.008			0.014/0.009		0.016/0.010			0.020/0.012		
	Z axis (positioning/repeatability)	mm	0.012/0.008			0.014/0.009		0.016/0.010			0.016/0.010		
CNC system	-	NEWAY FANUC[SIEMENS]					NEWAY FANUC[SIEMENS]						
Machine weight	kg	18000	22000	26000	20000	24000	25000	28000	35000	40000	50000		

Standard configuration:

Motorized spindle (HSK-A63) from Germany, spindle cooling system, spindle lubrication system, spindle air curtain protection system, Ram balance system, X/Y/Z axis roller guideway, X/Y/Z axis direct connection (no belt), all around protection (without PM20V), automatic chip conveying system, LED lighting and caution lights, handheld operation unit, Electric cabinet air-conditioning, centralized lubrication system, stainless-steel telescopic shield bed, anchor bolts and horizontal adjustment components, air and coolant tool cooling system, air gun, cutting compound oil-water separation device.

Options:

Different torque and spindle speed of motorized spindle, BT blind rivet and shank (8000rpm or below), coolant through spindle, grating ruler, tool magazine 4/32/40/60T, column height increase, rotary worktable, full protection (without PM20V), all around protection (PM20V), tool detection device, workpiece measuring device, water gun, CNC system with special functions.

[]Option

PM-U Series High-Speed 5 Axis Gantry Machining Center

- This type of machine adopts a moving worktable, fixed column gantry frame, five-axis, highly-automated;
- Equipped with world-class Kessler A&C rotary milling head to handle the complex curve processing of 5-axis;
- Adopted a double wound high torque motor and built-in spindle to simplify the transmission structure and improve the reliability of the machine;
- Good performance in dynamic reactions with 3 axis roller linear guide ways and 4 guideways layouts in Z-axis to achieve the balance between high rigidity and short reaction times;
- Suitable for Aerospace, Mold and Die, Defense industry and other complex curved parts processing like these.

1 Connecting and Matched Perfectly of Saddle and Beam

- Y-axis is arranged at the top and front of the beam, and the minimum distance between the lower guide and spindle center is designed.
- Combined with heavy-duty roller sliders, they effectively resist turning torque during machining, ensuring maximum dynamic response and static rigidity, providing a solid foundation for Precision Machining.

2 Headstock Parts

- Neway enlarged the size of the ram to let the ram extend to the ultimate span but remain rigid.
- 4 linear roller guide ways and roller packs imported to ensure Z axis work more effectively.

3 A&C Rotary Milling Head Offers 5 Axis Control

The main transmission is equipped with World-Class Kessler A&C rotary milling head to realize 5-axis moving and high spindle speed, high accuracy, and high efficiency.



Spindle Power Torque Diagram

External Dimensions

(Unit: mm)

PM20/25U Series

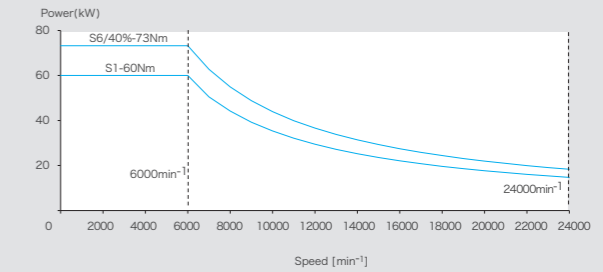
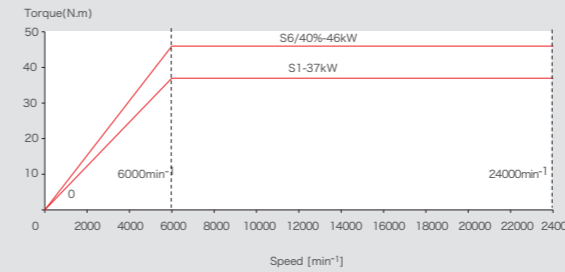

24000rpm spindle motor power & torque curve

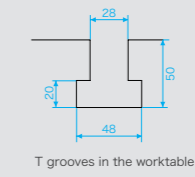
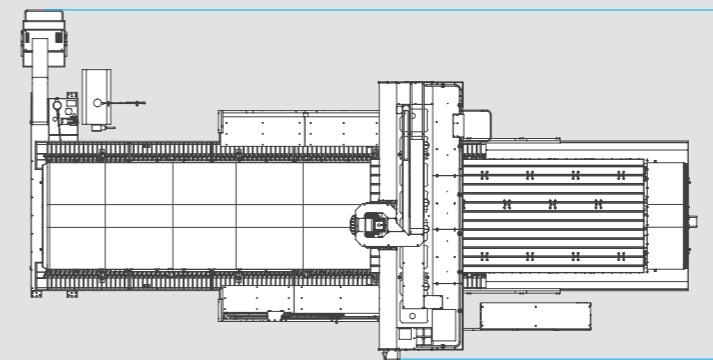
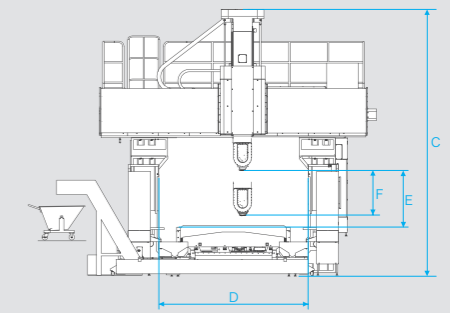
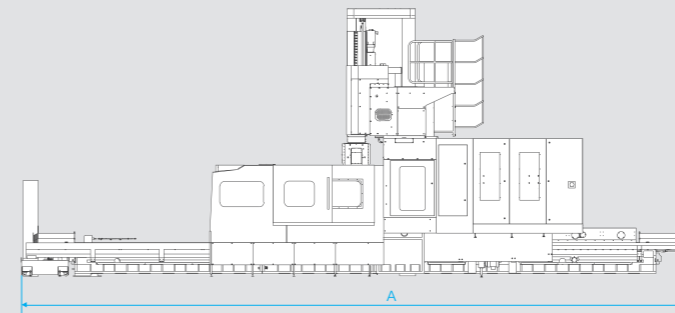

Type	A	B	C	D	E	F
	Length	Width	High	Column span	Spindle terminal to worktable	Z axis travel
PM2040U	11000	5500	6000	2800	1200	1000
PM2060U	15000					
PM2560U	16000	7000	6500	3300	1200	1000
PM2580U	21000					

High-speed Drive Spindle
High-speed Direct Drive Spindle
High-speed Built-in Spindle
High-speed 5 Axis
High-speed 5 Axis Bridge Moving Cross-rail
Moving column

PMB-U Series

High-speed 5 Axis Bridge Type Cross-rail Machining Center

- This type of machine adopts bridge type, moving beam, fixed worktable;
- X-axis adopts 4 guideways, double drive, X1, X2 using double-motor anti-backlash, to ensure it is stable and reliable;
- Equipped with World-Class Kessler A&C rotary milling head to realize complex curve process parts with 5-axis;
- Dual wound high-torque Motor + built-in spindle configuration simplifies drive mechanism and improves machine reliability;
- Suitable for Aerospace, Auto industry, Defense industry, Rail transit, Wind power, Aluminum alloy, Mold, etc.

Item		Unit	PM2040U	PM2060U	PM2560U	PM2580U
Worktable	Worktable width	mm	2000		2500	
	Worktable length	mm	4000	6000	6000	8000
	Table load	kg	20000	26000	30000	35000
Capacity	Worktable travel (X axis)	mm	4200	6200	6200	8500
	Carriage travel (Y axis)	mm	3200		3700	
	Ram travel (Z axis)	mm	1000		1000	
	Spindle terminal to worktable	mm	200-1200		200-1200	
	Column span	mm	2800		3300	
Five-axis Head	Tool shank size	-	HSK-A63		HSK-A63	
	Spindle speed	r/min	24000		24000	
	Max. output torque	N.m	60/73		60/73	
	Spindle motor power	kW	37/46		37/46	
	A/C axis indexing angle	°	±105/±360		±105/±360	
	A/C axis indexing positioning accuracy	arc-second	±5/±3		±5/±3	
Rapid travel	X/Y/Z axis rapid trave	m/min	15/15/10	12/15/10	12/12/10	10/12/10
ATC	Tool position	-	[24/32/40/60]		[24/32/40/60]	
	Max. tool diam./length/weight	mm/mm/kg	φ80/350/8		φ80/350/8	
Accuracy GB/T17421.2-2016 ISO 230-2:2006	Max. tool diameter (empty neighbor)	mm	φ150		φ150	
	X axis (positioning/repeatability)	mm	0.020/0.012	0.025/0.016	0.025/0.016	0.030/0.020
	Y axis (positioning/repeatability)	mm	0.017/0.010		0.020/0.012	
	Z axis (positioning/repeatability)	mm	0.012/0.008		0.012/0.008	
CNC system			SIEMENS[HEIDENHAIN]			
Machine weight		kg	45000	55000	65000	85000

Standard configuration:

5-axis milling head imported from Europe, A/C axis driven by torque Motor Directly, high-speed motorized spindle, spindle and A/c axis cooling system, spindle oil and air lubrication system, spindle temperature rise protection, spindle vibration protection, spindle air curtain protection, Ram balance system, X/Y/Z axis grating ruler, processing area protection, beam handrail and stairs, Automatic chip conveying system, LED lighting and caution lights, handheld operation unit, electric cabinet air-conditioning, centralized lubrication system, stainless-steel telescopic shield bed, anchor bolts and horizontal adjustment components, air and coolant tool cooling system, air gun, cutting compound oil-water separation device.

Options:

Single 5 axis milling head, different torque and spindle speed of motorized spindle, coolant through spindle, tool magazine 24/32/40/60T, column height increase, all around protection, tool detection device, workpiece measuring device, water gun, CNC system with special functions.

[]Option



High-speed

High-speed Direct Drive Spindle

High-speed Built-in Spindle

High-speed 5 Axis

High-speed 5 Axis Bridge Moving Cross-rail

Moving column

Spindle Power Torque Diagram

External Dimensions

(Unit: mm)

PMB20/25/30U Series

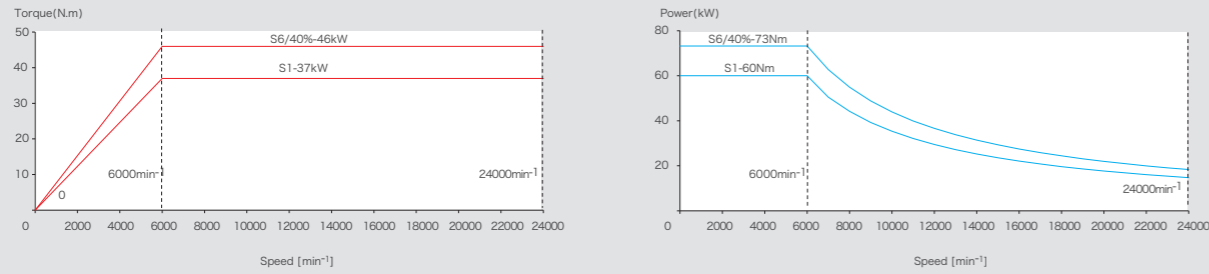

24000rpm spindle motor power & torque curve

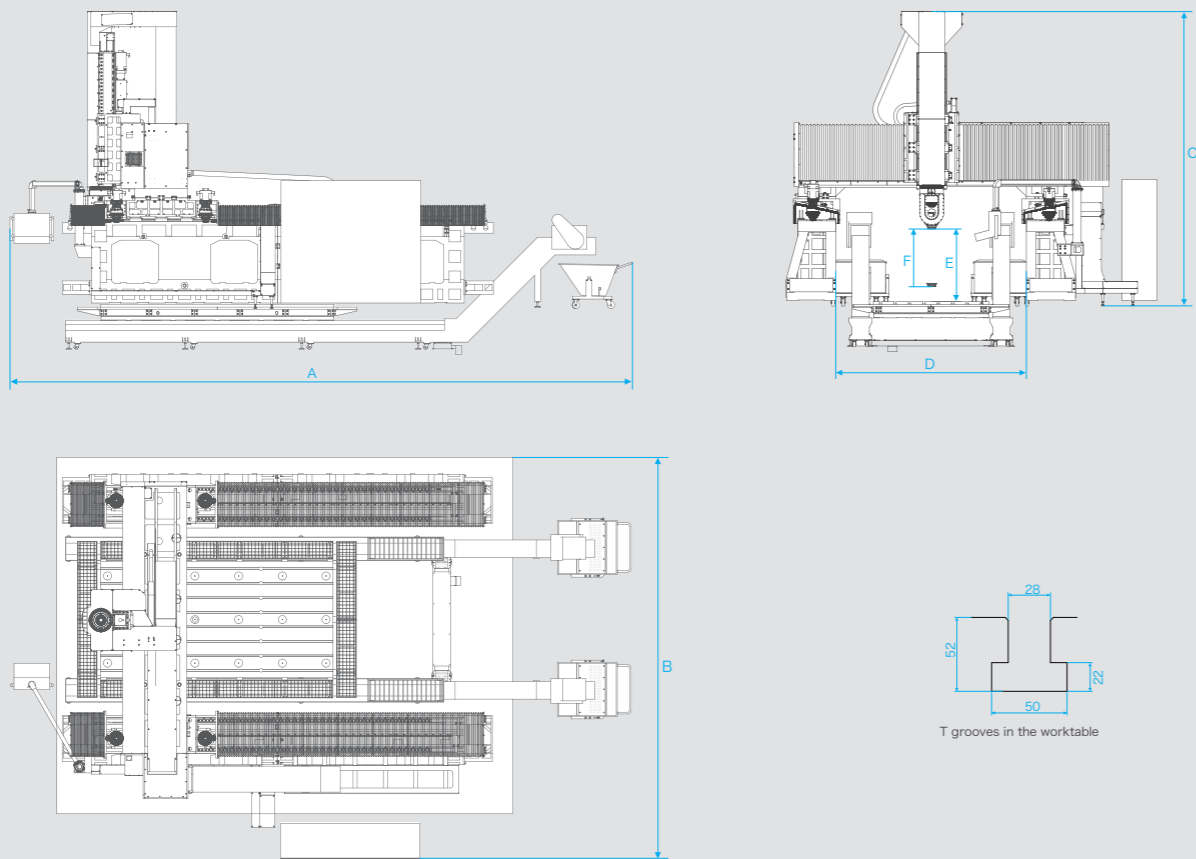

Type	A Length	B Width	C High	D Column span	E Spindle terminal to worktable	F Z axis travel
PMB2040U	10500	7000	5500	3300	1300	1000 [1250]
PMB2060U	12700					
PMB2540U	10500	7650	5500	3800	1300	
PMB2560U	12700					
PMB3060U	12700	8300	5750	4300	1300	

Item	Unit	PMB2040U	PMB2060U	PMB2540U	PMB2560U	PMB3060U
Worktable	Worktable width	2000		2500		3000
	Worktable length	4000	6000	4000	6000	6000
	Table load	5000		5000		5000
Capacity	Worktable travel (X axis)	4000	6000	4000	6000	6000
	Carriage travel (Y axis)	2300		2800		3300
	Ram travel (Z axis)	1000		1000		1000
	Spindle terminal to worktable	300-1300		300-1300		300-1300
	Column span	3300		3800		4300
Five-axis Head	Tool shank size	HSK-A63		HSK-A63		HSK-A63
	Spindle speed	24000		24000		24000
	Max. output torque	60/73		60/73		60/73
	Spindle motor power	37/46		37/46		37/46
	A/C axis indexing angle	±105/±360		±105/±360		±105/±360
	A/C axis indexing positioning accuracy	±5/±3		±5/±3		±5/±3
Rapid travel	X/Y/Z axis rapid trave	25/25/25		25/25/25		25/25/25
ATC	Tool position	[12/24/32]		[12/24/32]		[12/24/32]
	Max. tool diam./length/weight	φ80/350/8		φ80/350/8		φ80/350/8
Accuracy GB/T17421.2-2016 ISO 230-2:2006	Max. tool diameter (empty neighbor)	φ150		φ150		φ150
	X axis (positioning/repeatability)	0.020/0.012	0.030/0.020	0.020/0.012	0.030/0.020	0.030/0.020
	Y axis (positioning/repeatability)	0.016/0.010		0.020/0.012		0.025/0.016
	Z axis (positioning/repeatability)	0.012/0.008		0.012/0.008		0.012/0.008
CNC system	SIEMENS [HEIDENHAIN]					
Machine weight	kg	60000	70000	70000	90000	100000

Standard configuration:

5-axis milling head imported from Europe, A/C axis driven by torque Motor Directly, high-speed motorized spindle, spindle and A/c axis cooling system, spindle oil and air lubrication system, spindle temperature rise protection, spindle vibration protection, spindle air curtain protection, Ram balance system, X/Y/Z axis grating ruler, stainless-steel telescopic shield bed, all around protection, beam handrail and stairs, Automatic chip conveying system, LED lighting and caution lights, handheld operation unit, electric cabinet air-conditioning, centralized lubrication system, anchor bolts and horizontal adjustment components, air and coolant tool cooling system, air gun, cutting compound oil-water separation device.

Options:

Single 5 axis milling head, different torque and spindle speed of built-in spindle, coolant through spindle, tool magazine 12/24/40/60T, tool detection device, workpiece measuring device, water gun, CNC system with special functions.

High-speed
High-speed Direct Drive Spindle
High-speed Built-in Spindle
High-speed 5 Axis
High-speed 5 Axis Bridge Moving Cross-rail
Moving column

PM-MH Series Movable Column Gantry Machining Center

- This series offers gantry frame movement, fixed table, with a super-strong heavy load capacity;
- With the same travel parameters, the footprint is only 3/5 of the column-type gantry, saving space with a smaller footprint;
- X axis adopted the left and right two servo motors, total of four servo motors for dual-drive synchronous control, electrical control to eliminate the backlash, improve positioning accuracy and repeatability;
- X axis adopted two large-span heavy-duty roller linear guide rails, super-large column surface, to ensure gantry smooth and accurate operation.

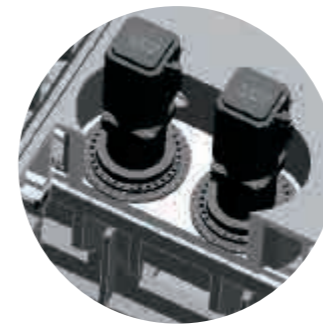

6 Main Transmission Drive

Adopt ZF Gearbox (1:1 and 1:4 two gears) and self-made gearbox (1:2) combination variable speed, effectively improve the spindle output torque, to meet the low speed high torque and large-scale constant power demand. Germany imported coupling between the main shaft and the gearbox, eliminating the traditional drive shaft structure, reducing the moment of inertia and noise, reducing the breakdown.

2 Y-axis Double Motor Drive

Y-axis drive also adopts the same two-motor master-slave control, with advanced slide and roller compound guideway, to achieve sensitive motion characteristics and good rigidity.

1 Z Axis Double Drive

The left and right sides double motor master-slave drive, over-center symmetrical layout, impact resistance, high precision, more stable transmission.

3 Y-axis Large Span Stepped Steel Guide Way

Large span cast iron stepped steel guide way with step difference up to 100mm for improved deflection and torsional resistance.

4 High Rigidity Spindle Design

500×500mm (20"×20") Super-Large Square Ram structure, surrounded by enclosed sliding guide rails, with guide grinding and plastic guide way technology, Neway Mills offer good abrasion resistance and excellent vibration absorption. The rigid design effectively reduced the vibrations of the sliding ram and ensured the accuracy of machining. This mill was clearly designed for powerful cutting.

500mm

5 Main Transmission Drive

ZF Gearbox (1:1 and 1:4 two gears) and Neway-made gearbox (1:2) combination variable speed, effectively improves the spindle output torque, to meet the low-speed high torque and large-scale constant power demand. Germany imported couplings offer connections between the main shaft and the gearbox that eliminates the traditional drive shaft structure, reducing the moment of inertia and noise, reducing power lost in translation.



Note: the features above are suitable for some machines

High-speed Drive Spindle
High-speed Direct Drive Spindle
High-speed Built-in Spindle
High-speed 5 Axis
High-speed 5 Axis Bridge Moving Cross-rail
Moving column

Spindle Power Torque Diagram External Dimensions

(Unit: mm)

PM30MH Series

PM30MHC Series

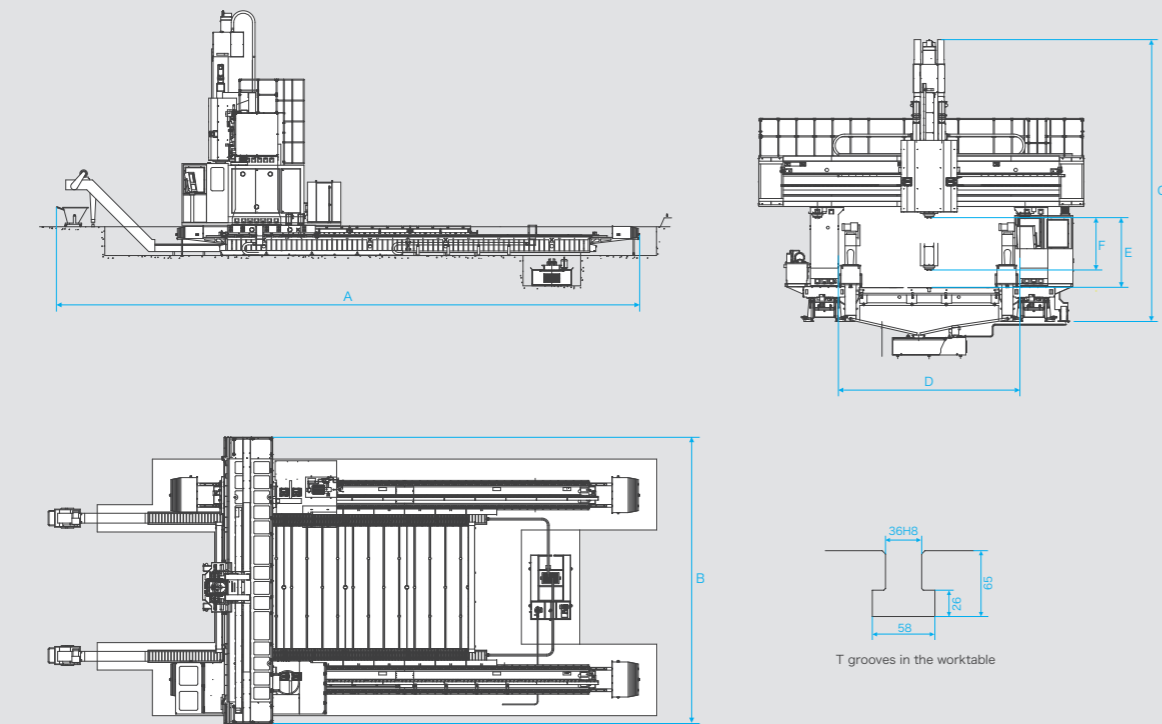
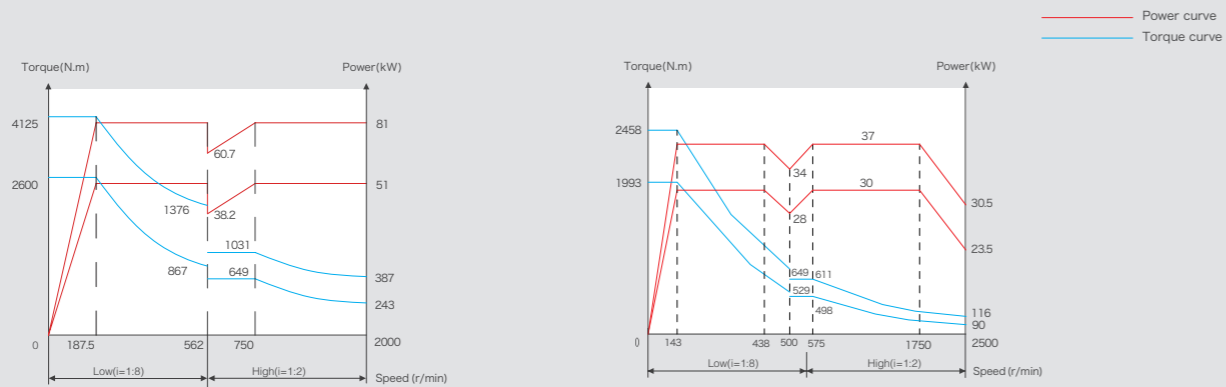

Type	A Length	B Width	C High	D Column span	E Spindle terminal to worktable	F Z axis travel
PM3080MH	19050	8500	8500	4200	2000	1500
PM30100MH	21050					
PM30120MH	23050					

Spindle Power Torque Diagram External Dimensions

(Unit: mm)

PM30MHZ Series

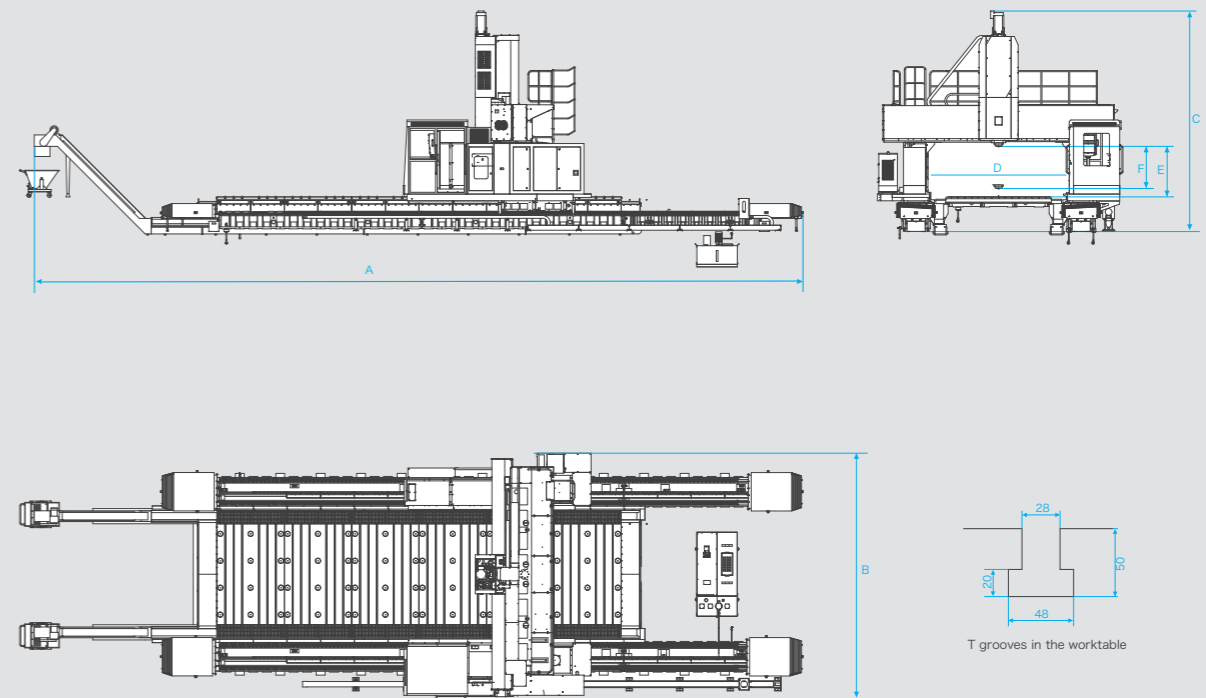
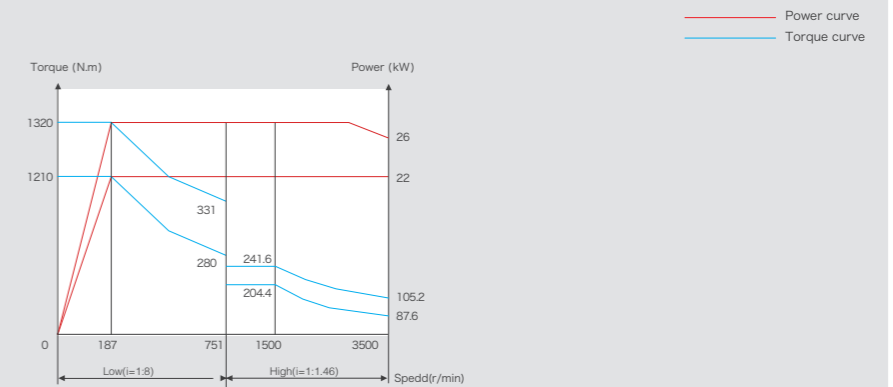

Type	A Length	B Width	C High	D Column span	E Spindle terminal to worktable	F Z axis travel
PM3080MHZ(MHC)	19000	7300	6550	4200	1500	1250
PM30100MHZ(MHC)	21000					
PM30120MHZ(MHC)	23000					
PM30140MHZ(MHC)	25000					
PM30160MHZ(MHC)	27000					

High-speed Drive Spindle
High-speed Direct Spindle
High-speed Burt-in Spindle
High-speed 5 Axis
High-speed 5 Axis Bridge Moving Cross-rail
Moving column

Item	Unit	PM3080MHZ	PM30100MHZ	PM30120MHZ	PM30140MHZ	PM30160MHZ	
Worktable	Worktable width	mm	3000				
	Worktable length	mm	8000	10000	12000	14000	16000
	Table load	kg/m ²	15000				
	T grooves	-	24	30	36	42	48
Capacity	Worktable travel (X axis)	mm	8500	10500	12500	14500	16500
	Carriage travel (Y axis)	mm	4600				
	Spindle box travel (Z axis)	mm	1250				
	Spindle terminal to worktable	mm	250-1500				
	Column span	mm	4200				
	Spindle	Tool shank size	-	BT50			
Rivet specifications		-	P50T-I (MAS403)				
Spindle speed		r/min	40-3500				
Max. output torque		N.m	1120/1320				
Spindle motor power		kw	22/26				
Cutting feed speed range		mm/min	6/6/6				
Rapid travel	X/Y/Z axis rapid travel	m/min	10/10/10				
ATC	Tool position	-	24/32/40/60				
	Max. tool diam./length /weight	mm/mm/kg	Φ125/350/20				
	Max. tool diameter (empty neighbor)	mm	Φ225				
	Accuracy GB/T17421.2:2016 ISO 230-2:2006	X axis (positioning /repeatability)	mm	0.05/0.030	0.055/0.034	0.060/0.038	0.065/0.042
Y axis (positioning /repeatability)		mm	0.03/0.020				
Z axis (positioning /repeatability)		mm	0.02/0.012				
CNC system	-	SIEMENS 828D [NEWAY FAUNC]					
Machine weight	kg	90000	100000	110000	120000	130000	

Standard configuration:

ZF retarder, full-protection square ram, spindle and retarder cooling system, short terminal spindle, spindle air shrouding protection system, Ram balance system, Gear-rack drive in X axis, X1/X2 double motors clearance, X/Y/Z axis grating rulers, processing area protection, beam handrail and stairs, automatic chip conveying system, LED lights and caution lights, handheld operation unit, electric cabinet air-conditioning , centralized lubrication system, stainless-steel telescopic shield bed, anchor bolts and horizontal adjustment components, air and coolant tool cooling system, air gun, cutting compound oil-water separation equipment.

[]Option

Item	Unit	PM3080MHC	PM30100MHC	PM30120MHC	PM30140MHC	PM30160MHC	PM3080MH	PM30100MH	PM30120MH	
Worktable	Worktable width	mm	30000					30000		
	Worktable length	mm	8000	10000	12000	14000	16000	8000	10000	8000
	Table load	Kg/m ²	15000					15000		
	Capacity	Worktable travel (X axis)	mm	8500	10500	12500	14500	16500	8500+500 (change head)	10500+500 (change head)
Carriage travel (Y axis)		mm	4600					4500(include change tool)		
Ram travel (Z axis)		mm	1250[1500]					1500		
Spindle terminal to worktable		mm	250-1500[300-1800]					500-2000		
Column span		mm	4200					4200		
Spindle		Tool shank size	-	BT50					BT50	
	Spindle speed	r/min	40-2500					20-2000		
	Max. output torque	N.m	1993/2458					2600/4125		
	Spindle motor power	kW	30/37					51/81		
	Ram section	mm	450×450					500×500		
	Rapid travel	X/Y/Z axis rapid travel	m/min	10/10/10					12/12/10	
ATC	Tool position	-	24/32/40/60					[24/32/40/60]		
	Max. tool diam./length /weight	mm/mm/kg	Φ125/350/20					Φ125/350/20		
	Max. tool diameter (empty neighbor)	mm	Φ225					Φ225		
	Accuracy GB/T17421.2:2016 ISO 230-2:2006	X axis (positioning /repeatability)	mm	0.050/0.030	0.050/0.034	0.060/0.038	0.065/0.042	0.070/0.046	0.050/0.030	0.050/0.030
Y axis (positioning /repeatability)		mm	0.030/0.020					0.035/0.025		
Z axis (positioning /repeatability)		mm	0.020/0.012[0.025/0.015]					0.025/0.015		
CNC system	-	NEWAY FAUNC [SIEMENS 828D]					SIEMENS [FANUC]			
Machine weight	kg	90000	100000	110000	120000	130000	120000	140000	155000	

Options:

Milling head, DIN/CAT/ISO blind rivet and shank, coolant through spindle, tool magazine 24/32/40/60T, Vertical and horizontal tool magazine 32/40/60T, rotary worktable, tool detection device, Workpiece measuring device, water gun, CNC system with special functions.

[]Option

High-speed
High-speed Direct Drive Spindle
High-speed Built-in Spindle
High-speed 5 Axis
High-speed 5 Axis Bridge Moving Cross-rail
Moving column

Milling Heads

Neway-made Angular Head

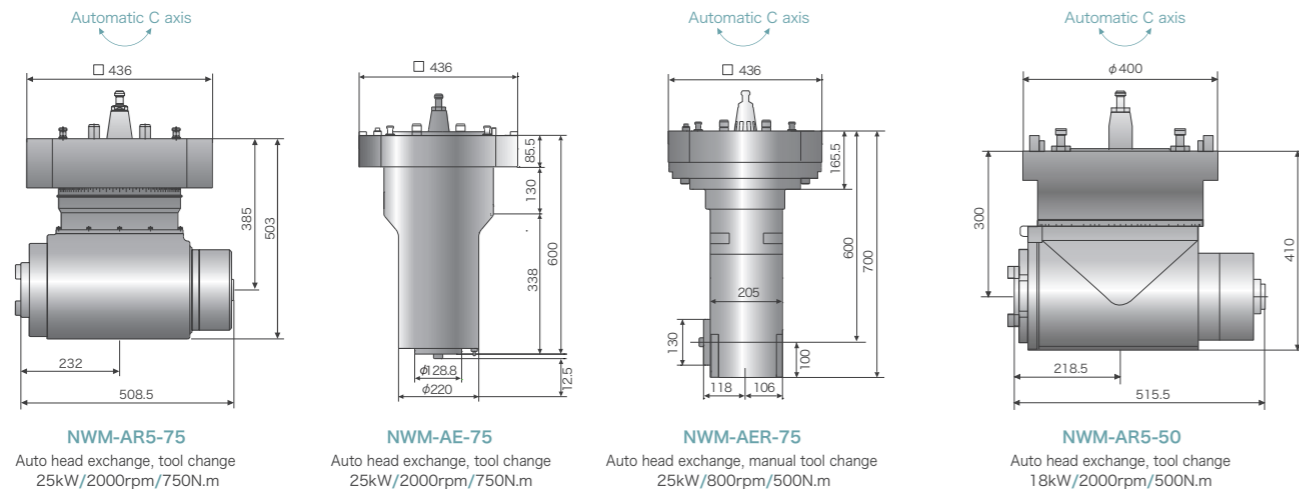

Economical Accessory Head

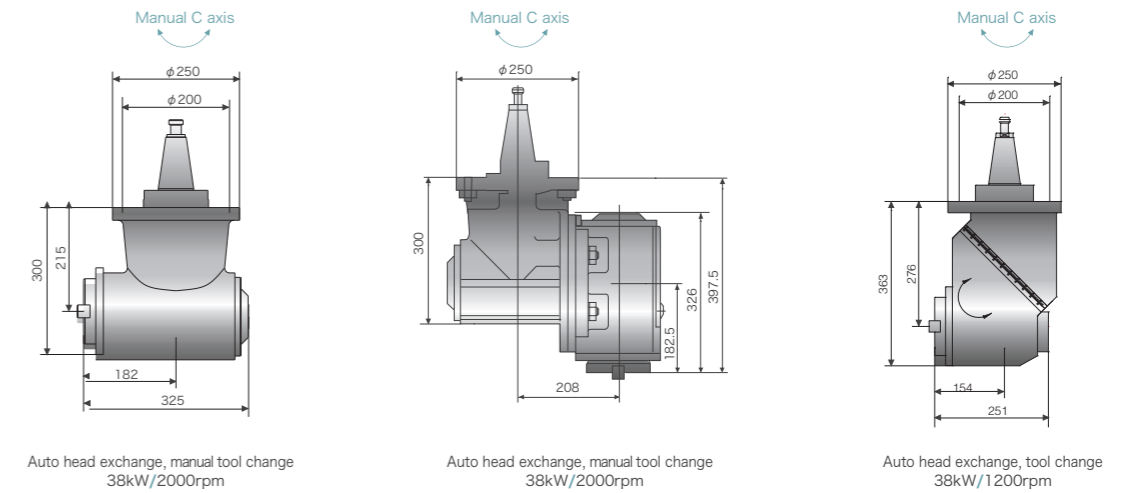

Taiwan Accessory Head

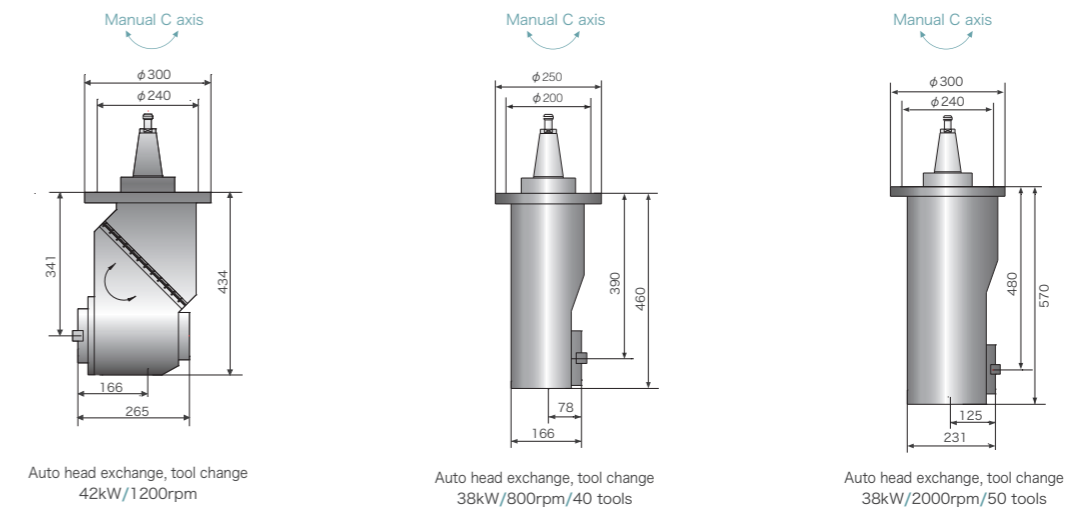
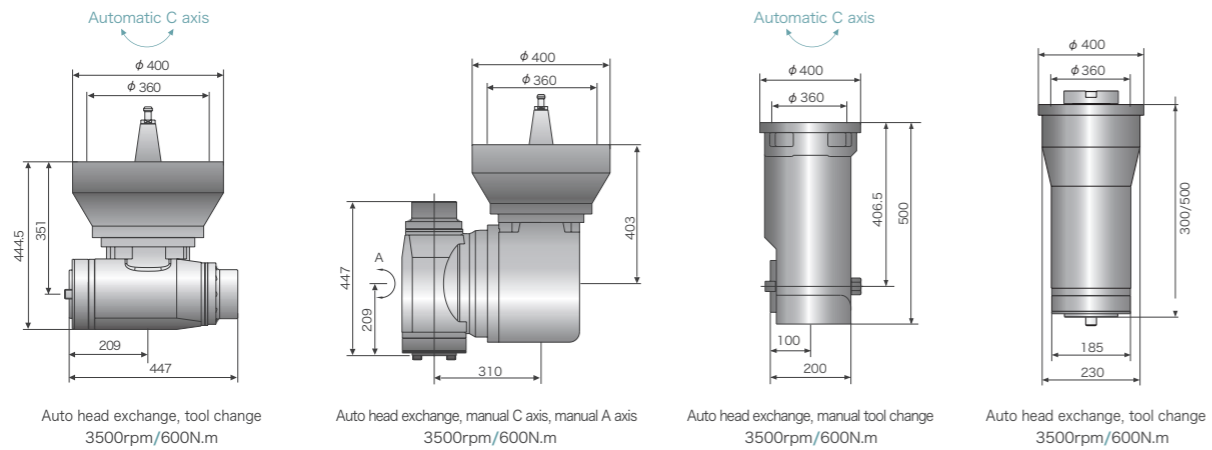

European Import Accessory Head

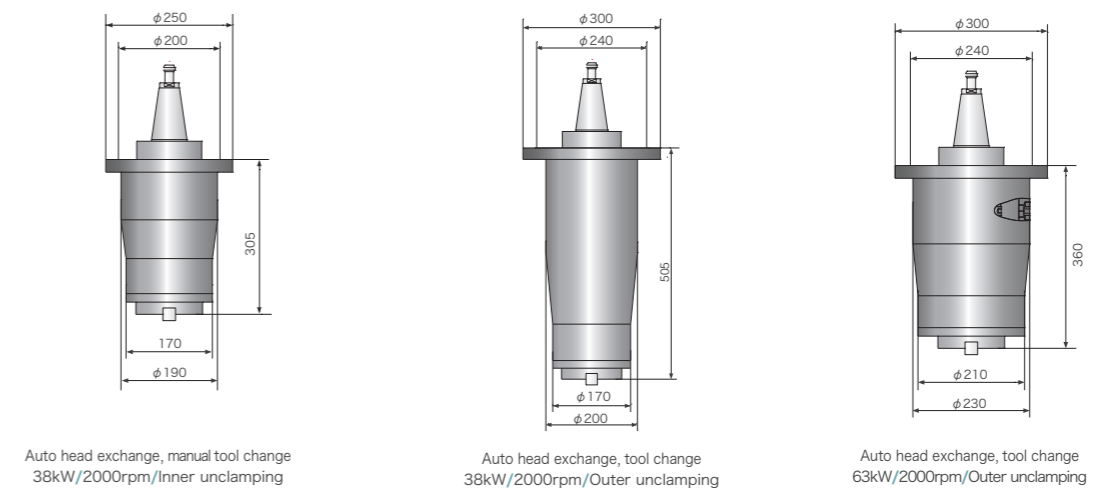
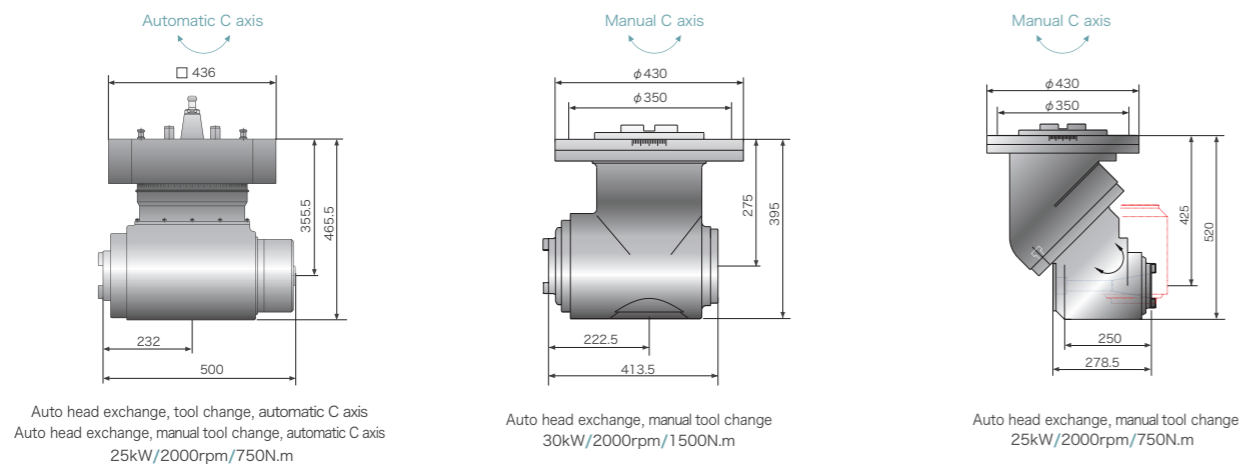

CNC System

Powerful system functionality combined with ongoing feature/function development greatly enhances the usability of the machine. The System will also provide, commissioning data, safety alarm removal, maintenance parameters, etc.

More Options

1 Machine Maintenance and Precautions

Describes the precautions regarding the use of the machine and display the buttons to enter other screens.

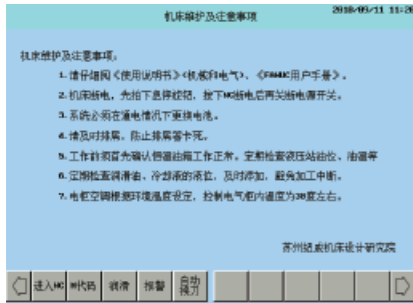

2 M Code

Common use of M code, no need to look up to the operation manual.



3 Alarm Help In Text

When the alarm appears, this screen can be used to find the corresponding solution, convenient for customers to use.

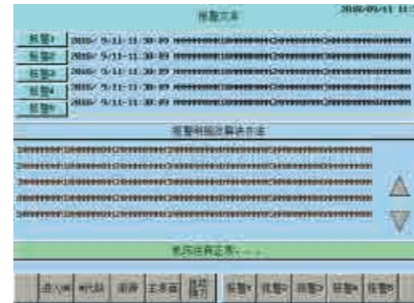

4 Lubrication Supporting Picture

Quickly set the dwell time of lubrication and lube intervals to see the working status of the lubricating pump.

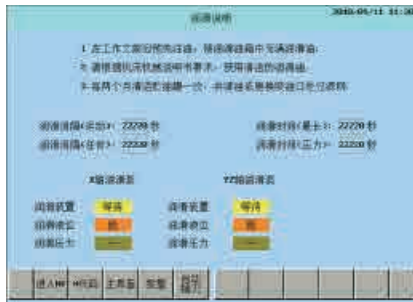

5 Vertical And Horizontal Tool Magazine Signal

Displays the signal status of the tool magazine, as well as the name of the tool on the tool magazine and spindle, to help customers handling the tool magazine's problems easier.

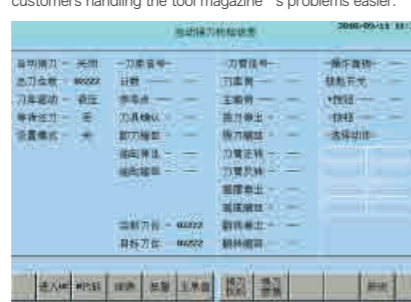

1 Choose Functions

Opens and Shields certain functions of the machine.

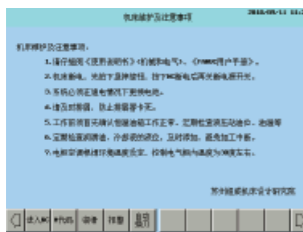

2 Vertical Tool Magazine Debugging

View ATC signal status and control ATC movements through the screen. Quickly corrects Tool change recovery by following on screen directions.



3 Vertical And Horizontal Tool Magazine Debugging

Set up the vertical and horizontal tool magazine functions. View the ATC status through the screen and set the tool replacement point.



4 Accessory Milling Head Debugging

View the signal status of angle head and set the position of indexing and clamping.



- 01 Disk type tool magazine
- 02 Vertical and horizontal chain type tool magazine
- 03 Glass scales
- 04 Coolant through the spindle
- 05 Raising block
- 06 Horizontal rotary worktable
- 07 The 4th axis
- 08 Tool measurement length and diameter
- 09 Laser probe